

RADIO & ELECTRONICS CONSTRUCTOR

JULY 1976

35p

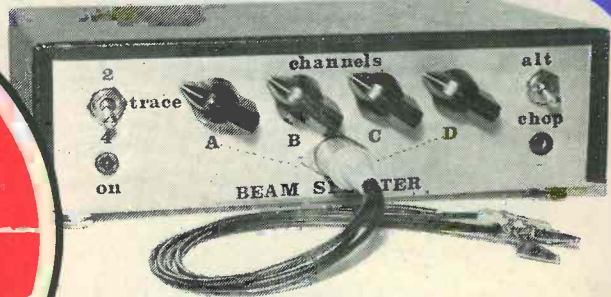
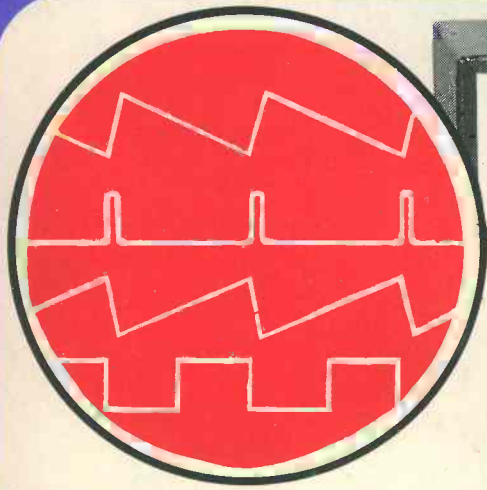

4-WAY BEAM SPLITTER

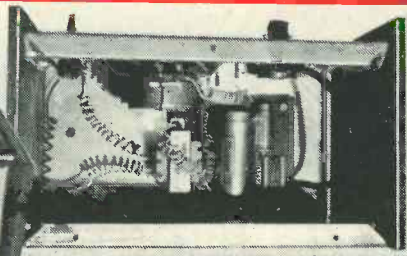
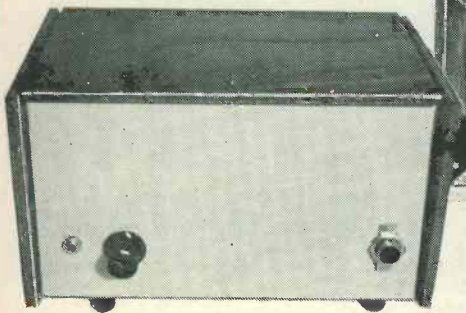

GENERAL PURPOSE I-C-AMPLIFIER

**ALSO
FEATURED**

**AUDIO CONTROL CIRCUITS — 1
ONE VALVE WORKING ON '160' AND '80'**



Each £3 unit of Home Unit Insurance gives you protection up to the limit shown

This is the simplified insurance you have been waiting for. Not just cover on the contents of your home but a package of personal protection you and your family need. And it's how we save you so much money: just ONE policy to issue instead of nine! You can build up to the cover you need by additional units

(or 1/4 units after the first) up to a maximum of five. So simple. So easy. Apply to your Broker, Agent or local office of a General Accident company. The Home Unit Policy can replace your existing insurances. And remember - as you buy more possessions just add more Home Units at any time. *Quote Ref. 20/9468*

THE GENERAL ACCIDENT FIRE & LIFE ASSURANCE CORPORATION LTD

Metropolitan House, 35 Victoria Avenue,
Southend-on-Sea, Essex, SS2 6BT

It pays to be protected by a **General Accident** company

Please send me further particulars of the Home Unit Insurance.

Name

Address

20/9468

RADIO & ELECTRONICS CONSTRUCTOR

JULY 1976

Volume 29 No. 12

Published Monthly (1st of Month)
First Published 1947

Incorporating The Radio Amateur

Editorial and Advertising Offices
57 MAIDA VALE LONDON W9 1SN

Telephone 01-286 6141 *Telegrams*
Databux, London

© Data Publications Ltd., 1976. Contents may only be reproduced after obtaining prior permission from the Editor. Short abstracts or references are allowable provided acknowledgement of source is given.

Annual Subscription: £5.00 (U.S.A. and Canada \$11.00) including postage. Remittances should be made payable to "Data Publications Ltd". Overseas readers please pay by cheque or International Money Order.

Technical Queries. We regret that we are unable to answer queries other than those arising from articles appearing in this magazine nor can we advise on modifications to equipment described. We regret that such queries cannot be answered over the telephone; they must be submitted in writing and accompanied by a stamped addressed envelope for reply.

Correspondence should be addressed to the Editor, Advertising Manager, Subscription Manager or the Publishers as appropriate.

Opinions expressed by contributors are not necessarily those of the Editor or proprietors.

Production.—Web Offset.

CONTENTS

GENERAL PURPOSE I.C. AMPLIFIER by F. G. Rayer	726
NEWS AND COMMENT	730
VOLTAGE-CONSCIOUS THYRISTOR CIRCUITS (Suggested Circuit 308) by G. A. French	732
AUDIO CONTROL CIRCUITS — 1 by P. R. Arthur	735
MEASURING MAINS CURRENT by J. Sneddon	741
SHORT WAVE NEWS — For DX Listeners by Frank A. Baldwin	742
4-WAY BEAM SPLITTER by B. Woodland and R. J. Woodland	744
TRADE NEWS	751
ONE VALVE WORKING ON '160' AND '80' by A. S. Carpenter	752
HOMODYNE S.S.B. RECEIVER For 80 metres — Part 2 by R. A. Penfold	756
IN YOUR WORKSHOP — Electronics A-Z	759
RADIO TOPICS by Recorder	764
VOLTAGE CALIBRATOR FOR OSCILLOSCOPES by C. F. Edwards	766
INDEX VOLUME 29—August 1975 to July 1976	774
ELECTRONICS DATA — No. 12 (For The Beginner — What Capacitors Do)	iii

Published in Great Britain by the Proprietors and Publishers, Data Publications Ltd, 57 Maida Vale, London W9 1SN

The *Radio & Electronics Constructor* is printed by Swale Press Ltd.

**AUGUST ISSUE WILL BE PUBLISHED
ON 2nd AUGUST**



WILMSLOW AUDIO

THE Firm for speakers!

SPEAKERS

Baker Group 25, 3, 8 or 15 ohms
 Baker Group 35, 3, 8 or 15 ohms
 Baker Group 50/12 8 or 15 ohms
 Baker Group 50/15 8 or 15 ohms
 Baker Deluxe 12" 8 or 15 ohms
 Baker Major 3, 8 or 15 ohms
 Baker Superb 8 or 15 ohms
 Baker Regent 12" 8 or 15 ohms
 Baker Auditorium 12" 8 or 15 ohms
 Baker Auditorium 15" 8 or 15 ohms
 Castle BRS/DD 4/8 ohms
 Celestion G12M 8 or 15 ohms
 Celestion G12H 8 or 15 ohms
 Celestion G12/50 8 or 15 ohms
 Celestion G12/50TC 8 or 15 ohms
 Celestion G15C 8 or 15 ohms
 Celestion G18C 8 or 15 ohms
 Celestion HF1300 8 or 15 ohms
 Celestion HF2000 8 ohms
 Celestion MH1000 8 or 15 ohms
 Celestion CO3K

Decca London ribbon horn
 Decca London CO/1000/8 Xover
 Decca DK30 ribbon horn
 Decca CO/1/8 Xover (DK30)

EMI 14 x 9 Bass 8 ohms 14A770
 EMI 8 x 5, 10 watt, d/cone, roll surr.
 EMI 6 1/2" d/cone, roll surr. 8 ohms
 Elac 59RM109 (15) 59RM114 (8)
 Elac 6 1/2" d/cone, roll surr. 8 ohms
 Elac 10" 10RM239 8 ohms
 Eagle Crossover 3000hz 3, 8 or 15 ohms
 Eagle FR4
 Eagle FR65
 Eagle FR8
 Eagle FR10
 Eagle HT15
 Eagle HT21
 Eagle MHT10
 Eagle FT28 multicell. horn

Fane Pop 15, 8 or 16 ohms
 Fane Pop 33T, 8 or 16 ohms
 Fane Pop 50, 8 or 16 ohms
 Fane Pop 55, 8 or 16 ohms
 Fane Pop 60, 8 or 16 ohms
 Fane Pop 70, 8 or 16 ohms
 Fane Pop 100, 8 or 16 ohms
 Fane Crescendo 12A, 8 or 16 ohms
 Fane Crescendo 128L, 8 or 16 ohms
 Fane Crescendo 15/100A, 8 or 16 ohms
 Fane Crescendo 15/125, 8 or 16 ohms

SPEAKERS

£8.64 Fane Crescendo 18, 8 or 16 ohms
 £10.25 Fane 910 Mk.II horn
 £14.00 Fane 920 Mk.II horn
 £18.62 Fane HPX1 crossover 200 watt
 £12.38 Fane 13 x 8, 15 watt dual cone
 £10.69 Fane 801T 8" d/c, roll surr.
 £16.31 Goodmans Axent 100
 £9.00 Goodmans Audiom 200 8 ohms
 £14.65 Goodmans Axiom 402 8 or 15 ohms
 £19.41 Goodmans Twinaxiom 8, 8 or 15 ohms
 £9.28 Goodmans Twinaxiom 10, 8 or 15 ohms
 £12.95 Goodmans 8P 8 or 15 ohms
 £15.95 Goodmans 10P 8 or 15 ohms
 £16.50 Goodmans 12P 8 or 15 ohms
 £18.00 Goodmans 12PG 8 or 15 ohms
 £28.95 Goodmans 12PD 8 or 15 ohms
 £34.50 Goodmans 12AX 8 or 15 ohms
 £6.98 Goodmans 15AX 8 or 15 ohms
 £8.55 Goodmans 15P 8 or 15 ohms
 £13.50 Goodmans 18P 8 or 15 ohms
 £4.46 Goodmans Hifax 750P
 £28.80 Goodmans 5" midrange 8 ohms
 £6.75 Gauss 12" 200 watt
 £17.25 Gauss 15" 200 watt
 £4.50 Jordan Watts Module, 4, 8 or 15 ohms

£11.92 Kef T27
 £3.56 Kef T15
 £3.93 Kef B110
 £3.39 Kef B200
 £3.83 Kef B139
 £3.83 Kef DN8
 £1.75 Kef DN12
 £5.51 Kef DN13 SP1015 or SP1017
 £8.66 Lowther PM6
 £11.08 Lowther PM6 Mk.I
 £14.06 Lowther PM7
 £3.96 Peerless KO10DT 4 or 8 ohms
 £6.13 Peerless DT10HFC 8 ohms
 £4.00 Peerless KO40MRF 8 ohms
 £8.10 Peerless MT225HFC 8 ohms
 £5.25 Richard Allan CA12 12" bass
 £8.75 Richard Allan HP85
 £12.50 Richard Allan LP88
 £15.50 Richard Allan DT20
 £17.95 Richard Allan CN8280
 £18.75 Richard Allan Super Disco 60W 12"
 £27.95 STC 4001G
 £37.95 Tannoy 10" HPD
 £39.95 Tannoy 12" HPD
 £49.95 Tannoy 15" HPD
 £57.95 Wharfedale Super 10 RS/DD 8 ohms

SPEAKER KITS

£67.95 Baker Major Module 3, 8 or 15 ohms each
 £15.75 Goodmans DIN 20 4 or 8 ohms each
 £36.95 Goodmans Mezzo Twln kit pair
 £2.50 Helme XLK 20 pair
 £5.50 Helme XLK 30 pair
 £8.96 Helme XLK 35 pair
 £7.60 Helme XLK 40 pair
 £13.46 Helme XLK 50 pair
 £19.80 KEFkit 1 pair
 £9.50 KEFkit III pair
 £9.86 Peerless 20-2 each
 £5.95 Peerless 30-28 each
 £6.25 Peerless 20-3 each
 £14.95 Peerless 50-4 each
 £16.50 Peerless 1060 pair
 £16.95 Peerless 1070 each
 £39.00 Peerless 1120 each
 £45.00 Richard Allan Twin assembly each
 £22.50 Richard Allan Triple 8 each
 £39.00 Richard Allan Triple 12 each
 £16.00 Richard Allan Super Triple each
 £4.05 Richard Allan RA8 Kit pair
 £84.00 Richard Allan RA82 Kit pair
 £96.00 Richard Allan RA82L Kit pair
 £129.00 Wharfedale Linton II Kit pair
 £15.36 Wharfedale Glendale 3XP Kit pair
 Wharfedale Dovedale III Kit pair

HI-FI ON DEMONSTRATION

In our showrooms:
 Akai, Armstrong, Bowers & Wilkins, Castle,
 Celestion, Dual, Goodmans, Kef, Leak, Pioneer,
 Radford, Richard Allan, Rotel, Tandberg, Trio,
 Videotone, Wharfedale, etc.

—Ask for our HiFi price list—

THIS MONTHS SPECIALS!

Pioneer PL12D £43.00, Pioneer PL15R £53.00,
 Pioneer SX434 £98.95
 Rotel RX202 £80.00
 Videotone Minimax II £39.00

We stock the complete Radford range of amplifiers, preamplifiers, power amplifiers, tuners etc., and also Radford Audio Laboratory equipment, low distortion oscillator, distortion measuring set, audio noise meter etc.

ALL PRICES INCLUDE VAT (Prices correct at 7/6/78)

Send stamp for free 32-page booklet
 "Choosing a Speaker"

All units guaranteed new and perfect
 Carriage and Insurance: Speakers 55p each,
 12" and up 85p each, Kits £1 each
 (£2 per pair), Tweeters & crossovers 33p each.

WILMSLOW AUDIO

DEPT REC
 LOUDSPEAKERS, MAIL ORDER AND EXPORT:
 SWAN WORKS, BANK SQUARE, WILMSLOW
 HIFI, RADIO & TV: SWIFT OF WILMSLOW, 5
 SWAN STREET, WILMSLOW CHESHIRE
 PA, HIFI & ACCESSORIES: WILMSLOW
 AUDIO, 10 SWAN STREET, WILMSLOW
 CHESHIRE
 TELEPHONE: LOUDSPEAKERS, MAIL ORDER
 AND EXPORT WILMSLOW 29599
 HIFI, RADIO ETC., WILMSLOW 26213

COMPLETE KITS IN STOCK FOR

**RADFORD STUDIO 90, RADFORD MONITOR 180,
 RADFORD STUDIO 270, RADFORD STUDIO 360,
 HIFI ANSWERS MONITOR (Rogers), HIFI NEW NO
 COMPROMISE (Frisby), HI FI NEWS
 STATE OF THE ART, WIRELESS WORLD
 TRANSMISSION LINE (Bailey), PRACTICAL HIFI &
 AUDIO MONITOR (Giles), PRACTICAL HIFI & AUDIO
 TRIANGLE (Giles), POPULAR HIFI (Colloms) ETC.**

Construction leaflets for Radford, Kef, Jordan Watts,
 Tannoy, HiFi Answers Monitor, Free on request

PA Amplifiers, microphones etc. by
 Linear, Shure, Eagle, Beyer, AKG etc.

FREE with orders over £10

"Hi-Fi Loudspeaker Enclosures" Book

SUMMERTIME SAIL-AWAY

SCORCHER
7490.25p
each.

WITH OUR
SIZZLING PRICES!!



PAK OFFERS

ALL U PAKS, UIC PAKS, *ULIC PAKS, AS SEEN IN OUR PREVIOUS ADVERTS
40p PER PAK
AVAILABLE AT

ZENER PAKS

400mW
PAK No:
1 containing 20 3v-10v
2 containing 20 11v-33v
£1.00 PER PAK*

RESISTOR PAKS

R1. 50 $\frac{1}{2}$ w 100 ohm-820 ohm
R2. 50 $\frac{1}{2}$ w 1K-8.2K
R3. 50 $\frac{1}{2}$ w 10K-82K
R4. 50 $\frac{1}{2}$ w 100K-1M

BUY ONE OF EACH
Special Price **£1.60 the 4***

R5. 30 $\frac{1}{2}$ w 100 ohm-820 ohm
R6. 30 $\frac{1}{2}$ w 1K-8.2K
R7. 30 $\frac{1}{2}$ w 10K-82K
R8. 30 $\frac{1}{2}$ w 100K-1M

BUY ONE OF EACH
Special Price **£1.60 the 4***

CAPACITOR PAKS

E1 18 Electrolytics 47 μ F-100 μ F
E2 18 Electrolytics 10 μ F-100 μ F
E3 18 Electrolytics 100 μ F-680 μ F

BUY ONE OF EACH
Special Price **£1.20 the 3***

MC1 24 Ceramic Caps 22pf-82pf
MC2 24 Ceramic Caps 100pf-390pf
MC3 24 Ceramic Caps 470pf-3300pf
MC4 21 Ceramic Caps 4700pf-0.047 μ F

BUY ONE OF EACH
Special Price **£1.60 the 4***

OPTOELECTRONICS

L.E.D. DISPLAYS
DL707 0.3" 70p
DL747 0.6" £1.50
DL127 0.5" £1.50
DOUBLE DIGIT 0.0-9.9 £1.80
I.T.T. NIXIE TUBES 5870 ST 1" FIGURES, LOWEST EVER PRICE 5 for £2.00
PHOTO CELLS ORP12/NSL4931 38p EACH
PHOTO TRANSISTORS OCP71 5 for £1.00

L.E.D.'s
RED: TIL209 0.125" or FLV117 0.2" 5 of either 50p
GREEN: TIL211 0.125" or FLV 0.2" 5 of either 75p
YELLOW: 0.125" Size or 0.2" Size 5 of EITHER 75p

CLIPS FOR LED'S 0.125" only, AVAILABLE AT 10 for 20p

IC's

NE 555 Timer 38p
NE556 Dual Timer 80p
709P 8 Pin DIL 15p
741P 8 Pin DIL 18p
747 14 Pin DIL 36p
748 8 Pin DIL 25p
uA711 Dual Comparator 25p
*72301 op. amp. TO99 25p
*72770 op. amp. TO99 50p

IC SOCKETS

BPS8 9p
BPS14 10p
BPS16 11p

TRIACS

2A/400PIV 50p
6A/400PIV 55p
10A/400PIV 75p

DIACS

BR100 15p
D32 15p

THYRISTORS

T05 1A50PIV 15p
1A/400PIV 25p
1A/600PIV 30p
T086 5A/50PIV 25p
5A/400PIV 40p
5A/600PIV 50p
T048 16A/50PIV 30p
16A/400PIV 60p

BRIDGE RECTIFIERS

2A/50 volt 25p
2A/100 volt 30p
2A/200 volt 35p
2A/400 volt 40p
2A/1000 volt 50p

FET's

2N3819 12p
2N5458 (MPF104) 15p

DIY PRINTED CIRCUIT KIT

Normal Price **£7.80**
Sale Price **£5.50**

CONTAINS 6 Pieces copper laminate, box of etchant powder and measure, tweezers, marker pen, high quality pump drill, Stanley knife and blades, 6 inch metal rule. FULL Easy to follow instructions.

TRANSISTORS

AC127 10p *BF198 12p
AC128 10p *BF199 12p
AC141K 20p BF257 19p
AC142K 18p BF258 20p
OC71 9p BF259 18p
BC107 6p BF263 15p
BC108 6p BF284 15p
BC109 6p 8FY50 15p
*BC147 8p BFY51 15p
*BC148 8p BFY52 15p
*BC149 9p 2N696 10p
*BC157 11p 2N697 11p
*BC158 10p 2N698 11p
*BC159 10p 2N706 8p
*BC169C 7p 2N708 8p
*BC170 5p 2N1613 15p
*BC172 5p 2N1711 15p
*BC178 12p 2N2219A 15p
*BC182 10p 2N2369 12p
*BC183 10p 2N2369A 12p
*BC184 10p 2N2905A 13p
*BC184L 11p *2N2926g 9p
*BC212 10p *2N3055 38p
*BC212L 10p *2N3055 38p
*BC213 10p *2N3702 8p
*BC213L 10p *2N3703 8p
*BC214 11p *2N3704 8p
*BC214L 11p *2N3705 8p
*BC327 12p *2N3706 8p
*BC328 12p *2N3903 8p
*BC337 11p *2N3904 8p
*BC338 11p *2N3905 9p
BD116 50p *2N3906 9p
BF167 10p *2N4080 9p
BF173 10p *2N5172 9p
*BF194 9p *ZTX300 5p
*BF195 9p *ZTX500 8p
*BF196 10p *ZTX107 5p
*BF197 10p *ZTX108 5p
*ZTX109 5p

DIODES

OA10 15p IN4001 24p
OA47 5p IN4002 3p
OA81 5p IN4003 34p
OA91 5p IN4004 4p
OA200/ BAX13 5p IN4005 44p
OA202 IN4006 5p
BAX16 5p IN4007 6p
IN914 4p 3 AMP
IN914 4p IN5400 11p
IN4148 4p IN5401 12p
IS44 4p IN5402 13p
IS920 5p IN5403 14p
IS923 5p IN5404 15p
IS970 5p IN5405 18p
BA100 6p IN5406 17p
BA148 10p IN5407 18p
IN5408 20p

VAT CHAT
Please add 12½% to prices marked *.
Remainder add 8%.

UNIUNCTION TRANSISTORS

UT46/TIS43 18p

VOLTAGE REGS

L129/ μ A7805 85p
L130/ μ A7812 85p
L131/ μ A7815 85p

DYNAMIC CASSETTE MIKE

With 2.5mm and 3.5mm Jack Plugs
£1.50*

P&P
Postage & Package add 25p. Overseas add extra for airmail.

BI-PAK

P.O. BOX 6, WARE, HERTS



"I MADE IT MYSELF"

Imagine the thrill you'll feel! Imagine how impressed people will be when they're hearing a programme on a modern radio you made yourself.

Now! Learn the secrets of radio and electronics by building your own modern transistor radio!

Practical lessons teach you sooner than you would dream possible.

What a wonderful way to learn - and pave the way to a new, better-paid career! No dreary ploughing through page after page of dull facts and figures. With this fascinating Technatron Course, you learn by building!

You build a modern Transistor Radio... a Burglar Alarm. You learn Radio and Electronics by doing actual projects you enjoy - making things with your own hands - things you'll be proud to own! No... it's so fast and easy to learn this way. Because learning becomes a hobby! And what a profitable hobby. Because opportunities in the field of Radio and Electronics are growing faster than they can find people to fill the jobs!

No soldering - yet you learn faster than you ever dreamed possible. Yes! Faster than you can imagine, you pick up the technical know how you need. Specially prepared step-by-step lessons show you how to read circuits - assemble components - build things - experiment. You enjoy every minute of it!

You get everything you need. Tools. Components. Even a versatile Multimeter that we teach you how to use. All included in the course. **AT NO EXTRA CHARGE!** And this is a course anyone can afford. (You can even pay for it by easy instalments).

So fast, so easy, this personalised course will teach you even if you don't know a thing today!

No matter how little you know now no matter what your background or education, we'll teach you. Step by step, in simple easy-to-understand language, you pick up the secrets of radio and electronics.

You become somebody who makes things, not just another of the millions, who don't understand. And you could pave the way to a great new career, to add to the thrill and pride you receive when you look at what you have achieved. Within weeks you could hold in your hand your own transistor radio. And after the course you can go on to acquire high-powered technical qualifications, because our famous courses go right up to City & Guilds levels.

Send now for FREE 44-page book - see how easy it is - read what others say!

Find out more now! This is the gateway to a thrilling new career, or a wonderful hobby you'll enjoy for years. Send the coupon now. There's no obligation.

POST TODAY FOR FREE BOOK

To: ALDERMASTON COLLEGE
DEPT. CRE 19, READING RG7 4PF **CRE 19**

Also at our London Advisory Office, 4 Fore Street Avenue, Moorgate, London, EC2Y 5EJ Tel: 01-628 2721
Yes, I'd like to know more about your course. Please send me free details—plus your big, 76-page book that tells about all your courses.

NAME

ADDRESS

POSTCODE



HOME OF BRITISH INSTITUTE OF ENGINEERING TECHNOLOGY

LATEST BOUND VOLUME No. 28

of

"Radio & Electronics Constructor"



AUGUST 1971 to JULY 1975

Comprising 768 pages **PRICE £2.75 P&P 75p inc. index**

BOUND VOLUME No. 25 (August 1971 to July 1972)

BOUND VOLUME No. 27 (August 1973 to July 1974)

PRICES

VOL. 25

£2.00 per volume P&P 75p

VOL. 27

£2.40 per volume P&P 75p

Limited number of these volumes still available.

We regret all earlier volumes are now completely sold out.

Available only from
DATA PUBLICATIONS LTD., 57 MAIDA VALE, LONDON, W9 1SN

RETURN OF POST MAIL ORDER SERVICE

NEW BSR HI-FI AUTOCHANGER

STEREO AND MONO

Plays 12" 10" or 7" records
Auto or Manual. A high
quality unit backed by BSR
reliability with 12 months
guarantee. AC 200/250v.
Size 13 1/2 x 11 1/2 in.
Above motor board 3 1/2 in.
Below motor board 2 1/2 in.



With STEREO/MONO CARTRIDGE £10.95 Post 75p

PORTABLE PLAYER CABINET £4.50

Modern design. Size 16" x 15" 7" approx. Post 50p
Large front grille. Hinged Lid. Chrome fittings.
Motor board cut for Garrard or BSR deck.
Rexine covered, in red and black.

HEAVY METAL PLINTHS

With P.V.C. Cover. Cut out for most
B.S.R. or Garrard decks. Silver grey
finish. Size 12 1/2 x 14 1/2 x 7 1/2 in.
Size 16 x 13 1/2 x 7 in. £6.95.

£5.95

Post 75p

TINTED PLASTIC COVERS

Sizes: 'A' - 14 1/2 in. x 12 1/2 in. x 4 1/2 in. £2.50. 'B' - 20 1/2 in.
x 12 1/2 in. x 4 1/2 in. £3.00. 'C' - 17 1/2 in. x 13 1/2 in. x 3 1/2 in. £3.25.
Ideal for record decks, tape decks, etc. Post 45p



R.C.S. DISCO DECK SINGLE RECORD PLAYER

Fitted with auto stop, stereo/comp. cartridge. Base-
plate. Size 11 in. x 8 1/2 in. Turntable. Size 7 in. diameter. A/C
finish. Size 220/250V motor has a separate winding 14 volt
to power a small amplifier. 3
speeds plays all size records.
Two for £12.

£6.25 Post 45p

COMPLETE STEREO SYSTEM

Two full size loudspeakers 13 1/2 x 10 x 3 1/2 in. Player
unit clips to loudspeakers making it extremely compact.
Overall size only 13 1/2 x 10 x 8 1/2 in. 3 watts per channel.



Attractive
Teak finish
Weight 13lbs.

Bargain Price

£22.50 85p carriage

SMITH'S CLOCKWORK 15 AMP TIME SWITCH 0-6 HOURS

Single pole two-way surface mounting with fixing screws.
Will replace existing wall switch to give light for return
home, garage, automatic anti-burglar lights etc. Variable
knob. Turn on or off at full or intermediate settings.
Fully insulated. Makers last list price £4.50. Brand new and
fully guaranteed.

OUR PRICE £2.95 Post 35p.

CASSETTE RECORDER MOTOR ONLY. 6 Volt.

Will replace many types. Ideal for models. £1.25

BLANK ALUMINIUM CHASSIS, 18 s.w.g. 2 1/2 in. sides
6 x 4 in. 70p; 8 x 6 in. 90p; 10 x 7 in. £1.15;
14 x 9 in. £1.50; 16 x 6 in. £1.45; 12 x 3 in. 87p;
16 x 10 in. £1.70.

ALUMINIUM PANELS 18s.w.g. 6 x 4 in. 15p; 8 x 6 in. 25p;
10 x 7 in. 30p; 12 x 5 in. 30p; 12 x 8 in. 40p; 16 x 10 in. 45p;
14 x 9 in. 50p; 12 x 12 in. 55p; 16 x 10 in. 75p.
ALUMINIUM ANGLE BRACKET 6 in. long x 1/2 x 1/2 in. 20p.

1 1/2 inch DIAMETER WAVECHANCE SWITCHES 45p. EA.
2 p. 2-way, or 2 p. 6-way, or 3 p. 4-way.
1 p. 1. 2-way, or 4 p. 2-way, or 4 p. 3-way.

TOGGLE SWITCHES. sp. 20p; dp. 25p dp. dt. 30p.

R.C.S. GENERAL PURPOSE TRANSISTOR PRE-AMPLIFIER BRITISH MADE

Ideal for Mike, Tape P.U., Guitar, etc. Can be used with Battery
9-12v. or H.T. line 200-300V. D.C. operation. Size 1 1/2 x 1 1/2 x 1 1/2 in.
Response 25 cps. to 25 Kc/s. 2¢ db gain. Post
For use with valve or transistor equipment. £1.45 30p
Full instructions supplied. Details S.A.E.

NEW ELECTROLYTICS

2/350V 20µ 250/25V 18p 16+16+16/275V 45p
4/350V 20p 600/25V 20p 50+50/300V 50p
8/350V 22p 100+100/275V 65p 32+32/450V 75p
16/350V 30p 150+200/275V 70p 100+50+50/350V 85p
32/500V 50p 8+8/450V 50p 32+32+32/350V 75p
25/25V 10p 8+16/450V 50p 3000/25V 95p
50/50V 10p 16+16/450V 50p 4700/63V 95p
100/25V 10p 32+32/350V 50p

LOW VOLTAGE ELECTROLYTICS

22, 25, 50, 68, 150, 470, 500, 680, 1500, 2200, 3300.
mfd all 6 volt 10p ea.
22, 25, 68, 100, 150, 200, 220, 330, 470, 680, 1000, 1500, 2200, mfd all 10 volt 10p ea.
220, 330, 1000, 4700, mfd all 4v. 10p ea.
1, 2, 4, 5, 8, 16, 25, 30, 50, 100, 200mF 15V 10p.
100mF 12V 20p. 25V 35p. 50V 47p. 100V 70p.
200mF 6V 25p. 25V 42p. 50V 57p. 4700/63V 95p.
2500mF 50V 62p. 3000mF 25V 47p. 50V 65p.
5000mF 6V 25p. 12V 42p. 25V 75p. 35V 85p. 50V 95p.
500V-0.001 to 0.1. 10p. 0.25. 12p. 0.47 25p.
CERAMIC 1µF to 0.01mF. 5p. Silver Mica 2 to 5000pF. 5p.
PAPER 350V-0.1-7p. 0.5-18p. 1mF or 2mF 150V 15p.
MICRO SWITCH single pole changeover 20p.
MICRO SWITCH sub min 25p.
TWIN GANG. "O-O" 208pF + 178pF £2. TWIN 365pF 60p.
Slow motion drive 365pF + 365pF with 25pF + 25pF 50p.
500PF standard twin gang 75p. 120 PF twin gang 50p.

ELAC 9 x 5 in. HI-FI SPEAKER, TYPE 59RM.
THIS FAMOUS AND WIDELY USED UNIT
NOW AVAILABLE AT BARGAIN PRICE
10 WATT, 8 OHM, CERAMIC MAGNET. £3.45

NEON PANEL INDICATORS, 250V Red or Amber, 30p
RESISTORS, 1/2w, 1w, 20%, 2p, 2w, 8p, 10 to 10M.
HIGH TOLERANCE, 1/2w, 2% 10 ohms to 10 meg. 12p.
Ditto 5%, Preferred values, 10 ohms to 10 meg. 5p.
WIRE WOUND RESISTORS, 5 watt, 10 watt, 15 watt,
10 ohms to 100K. 12p each. 0.5 ohm to 0.2 ohms 15p.
TAPE OSCILLATOR COIL. Valve type 35p.
FERRITE ROD 6" x 1/2" 30p; 6" x 1/4" 20p; 3" x 1/2" 10p.

MAINS TRANSFORMERS

ALL POST 50p each
250-0-250V 80mA. 6-3. 2A £2.95
250-0-250 80mA. 6-3v 3.5A. 6-3v 1a or 5v 2a £4.60
350-0-350 80mA. 6-3v 3.5A. 6-3v 1a or 5v 2a £5.80
300-0-300 120mA. 6-3v 4a C.T. 6-3v 2A £7.00
220v 45mA. 6-3v 2A £1.75
HEATER TRANS. 6-3v 3 amps. £1.45 1amp. 95p
GENERAL PURPOSE LOW VOLTAGE. Tapped outputs
2 amp 3, 4, 5, 6, 8, 9, 10, 12, 15, 18, 24, 30V £4.60
1 amp 6, 8, 10, 12, 16, 18, 20, 24, 30, 36, 40, 48, 60, £4.60
2a, 6, 8, 12, 16, 18, 20, 24, 30, 36, 40, 48, 60, £7.00
3a, 6, 8, 10, 12, 16, 18, 20, 24, 30, 36, 40, 48, 60, £8.70
5a, 6, 8, 10, 12, 16, 18, 20, 24, 30, 36, 40, 48, 60, £11.25
5, 8, 10, 16v 1a £2. 6-0-6V 500mA £1.9v 1a £1
12v 300mA £1. 12v 500mA £1. 12v 750mA £1.
40v 2a tapped 10v or 30v £2.50. 20v 3a £2.
40v 3a £2.50 30v 5A and 34v 2A ct. £3.95
AUTO TRANSFORMERS. 115v to 230v or 230v to 115v
150w £5. 250w £6. 400w £7. 500w £8.
CHARGER TRANSFORMERS. Input 200/250v
for 6 or 12v 1 1/2 £2.75 4a £4.60.
FULL WAVE BRIDGE CHARGER RECTIFIERS:
6 or 12v outputs 1 1/2a 40p; 2a 55p; 4a 85p.

R.C.S. STABILISED POWER PACK KIT

All parts including printed circuit and instructions to
build this unit. Voltages available: 5v, 7.5v, 9v, 12v.
Up to 100mA output. Post
Please state voltage required. £2.95 45p

R.C.S. 3 WAY CROSSOVER

Complete with 12ft twin lead fitted with din speaker plug.
Ready assembled with leads for speakers, bass, mid and
tweeter. Crossover frequencies -950 cps and
3,000 cps. For systems up to 25 watts. £2.20

VOLUME CONTROLS 80 Ohm Coax 8p yd.

5K ohms to 2 Meg. LOG or
LIN. L/S 25p. D.P. 40p
STEREO L/S 55p. D.P. 75p
Edge 5K. S.P. Transistor 25p

STANDARD VHF TYPE

FRINGE LOW LOSS. 15p per
Ideal 625 and colour. 15p yd

NEW 150 WATT BAKER PROFESSIONAL MIXER/
AMPLIFIER. Four inputs with volume controls plus
master volume, treble and bass; slave output. Speaker
matching 4 to 16 ohms. DISCOUNT PRICE £68. post £1.

E.M.I. 13 1/2 x 8 in.

SPEAKER SALE!

With tweeter £5.25
4w/ crossover, 10 Post 45p
watt. 5 or 8 ohm Post 45p
15 watt version £7.95
8 or 15 ohm
20 watt version £8.95
8 or 15 ohm
as illustrated
Bass units only £6.95
Post 65p



Bookshelf Cabinet £6.95

16 x 10 x 9 in. Teak Veneer Post 75p
For above units

R.C.S. 10 WATT AMPLIFIER KIT



This kit is suitable for record players, tape play back,
guitars, electronic instruments or small P.A. systems.
Two versions are available: A mono kit or a stereo kit. The
mono kit uses 13 semiconductor. The stereo kit uses 22
semiconductors with printed front panel and volume,
bass and treble controls. Spec. 10 watts output into 8
ohm, 7 watts into 15 ohms. Response 20 cps to 30K/cps.
Input 100 mV high imp. Size 9 1/2 in x 3 in x 2 in.

Mono kit £11.25 Stereo kit £17.50 post 45p

LOUDSPEAKERS P.M. 3 ohms 7 x 4 in. £1.25; 6 in. £1.50;
8 x 5 in. £1.60; 8 in. £1.75; 10 x 6 in. £1.90; 10 in. £2.50.
SPECIAL OFFER LOUDSPEAKERS! All Brand New.
3 ohm, 2 1/2 in; 2 1/2 in; 3 in; 5 in; 8 ohm, 2 1/2 in; 5 x 3 in;
5 in; 15 ohm, 3 1/2 in; 5 in; 6 x 4 in; 5 x 3 in; 7 x 4 in;
25 ohm, 2 1/2 in; 3 in; 5 x 3 in; 35 ohm, 3 in; 5 in;
60 ohm, 2 1/2 in; 2 1/2 in; 120 ohm, 3 in. £1.25 EACH

LOUDSPEAKER VOLUME CONTROL 15 ohm 10 watt
with 1 in. long threaded bush for wood panel
mounting 75p

RICHARD ALLAN TWIN CONE LOUDSPEAKERS. 8 in.
diameter 4W £2.50; 10 in. diameter 5W £2.95; Post 25p.
12 in. diameter, 6W £3.50; 3 or 8 or 15 ohm models.
SPEAKER COVERING MATERIALS. Samples Large S.A.E.
Horn Tweeters 2-18Kcs, 10W 8 ohm or 16 ohm £3.60
De Luxe Horn Tweeters 2-18 Kcs, 15W 8 ohm £.80
TWO WAY 3,000 cps CROSS OVERS 3 or 8 or 15 ohm £1.90
3-WAY CROSSOVER 850 cps and 3000 cps (25 watt) £2.20

GOODMANS CONE TWEETER

18,000 cps, 25 watts, 8 ohm. Price £3.25

ELECTRO MAGNETIC PENDULUM MECHANISM

1.5v d.c. operation over 250 hrs continuous on SP2 battery.
Fully adjustable swing and speed. Ideal displays teaching
electro magnetism or for metronome; store etc. 95p. Post 20p

WEYRAD TYPE COILS

P50/1AC 60p RA2W 85p 1 twin Gang £2
P50/2CC 40p OPT1 65p Printed £2
P50/3CC 40p LFD4 65p Circuit 85p

COAXIAL PLUG 10p. PANEL SOCKETS 10p. LINE 18p.
OUTLET BOXES. SURFACE MOUNTING 25p.
BALANCED TWIN RIBBON FEEDER 300 ohms. 7p yd.
JACK SOCKET Std. open-circuit 20p. closed circuit 25p.
Chrome Lead Socket 45p. Phono Plugs 10p. Phono Socket 8p.
JACK PLUGS Std. Chrome 30p; 3.5mm Chrome 15p. DIN
SOCKETS Chassis 3-pin 10p, 5-pin 10p. DIN SOCKETS
Lead 3-pin 18p, 5-pin 15p. DIN PLUGS 3-pin 18p; 5-pin
25p. VALVE HOLDERS 5p. CERAMIC 10p; CANS 5p.

R.C.S. 100 WATT VALVE AMPLIFIER CHASSIS



Professional model. Four inputs. Treble, Bass, Master
Volume Controls. Ideal disco, P.A. or groups. 5 speaker
outputs, very robust job £85 plus £1.50 carr.

NEW 'DISCO 100 WATT' PROFESSIONAL TRANSISTOR AMPLIFIER CHASSIS £52
2 inputs. 4 outputs separate volume treble Carr. £1
and bass controls. Ideal disco or slave amplifier chassis.

RADIO COMPONENT SPECIALISTS

Minimum post 30p.

Access and Barclaycard welcome

Open 9-6 Wed. 9-1 Sat. 9-5 (Closed for lunch 1.15-2.30)

Components Lists 10p.

Cash price includes VAT

Rail Selhurst.

Tel. 01-684 1665

JULY 1976

717

COMPONENTS

HOBBYIST - PROFESSIONAL - DOMESTIC - SURPLUS - INDUSTRIAL
 JUST A FEW OF OUR BARGAINS ARE LISTED BELOW - SEND STAMPED
 ADDRESSED ENVELOPE FOR A QUOTE ON OTHER REQUIREMENTS.
 PAY US A VISIT. OVER 90% OF STOCK BELOW QUANTITY
 WHOLESALE PRICE. RETURN POSTAL SERVICE UNLESS CHEQUE.

Goods sent at customer's risk, unless sufficient payment for registration (1st class letter post) or compensation fee (parcel post) included.

VALVE BASES	
Printed circuit B9A-B7G	4p
Chassis B7-B7G	8p
Shrouded chassis B7G-B9A	10p
B8A-B9A chassis-B12A tube	10p

Speaker 6" x 4" 5 ohm ideal for car radio **£1.25**

TAG STRIP - 6 way 3p	VHF Radio Tuner Head
9 way 5p Single 1p	Takes ECC 85

BOXES - Grey polystyrene 61 x 112 x 31mm, top secured by 4 self tapping screws **32½p**

Clear perspex sliding lid, 46 x 39 x 24mm **10p**

ABS, ribbed inside 5mm centres for P.C.B., brass corner inserts, screw down lid, 50 x 100 x 25mm orange **48p**; 80 x 150 x 50mm black **70p**; 109 x 185 x 60mm black **£1.04**

ALUMINIUM	
3" x 2" x 1"	39p
2¾" x 5¼" x 1½"	48p
4" x 4" x 1½"	45p
4" x 2¾" x 1½"	46p
4" x 2½" x 2"	46p
4" x 5¼" x 1½"	54p
6" x 4" x 2"	65p
7" x 5" x 2½"	79p
8" x 6" x 3"	99p
10" x 4½" x 3"	£1.02
12" x 5" x 3"	£1.20
10" x 7" x 3"	£1.22
12" x 8" x 3"	£1.50

SWITCHES		
Pole	Way	Type
4	2	Sub. Min. Slide
6	2	Slide
4	2	Lever Slide
2	2	Slide
1	3	13 amp small rotary
2	2	Locking with 2 to 3 keys

2 Amp 250V A.C. rotary **24p**

Wafer Rotary, all types **30p**

S.P.S.T. 10 am 240v. white rocker switch with neon. 1" square flush panel fitting **45p**

S.P.S.T. dot 13 amp, oblong, push-fit rocker **20p**

AUDIO LEADS
 5 pin din plug 180° both ends ½ Mtr., **80p**
 3 pin din to open end, 1½yd twin screened **35p**
 Phono to Phono plug, 6ft. **35p**

COMPUTER AND AUDIO BOARDS
 VARYING PANELS WITH ZENER, GOLD BOND, SILICON, GERMANIUM, LOW AND HIGH POWER TRANSISTORS AND DIODES, HI STAB RESISTORS, CAPACITORS, ELECTROLYTICS, TRIMPOTS, POT CORES, CHOKES ETC.
 3lb for **85p +75p** post and packing
 7lb for **£1.95+£1** post and packing

Skeleton Presets Slider, horizontal or vertical standard or submin. 5p	3" Tape Spools 8p 1" Terry Clips 4p 12 Volt Solenoid 30p
---	---

KNOBS
 SILVER METAL PUSH ON WITH POINTER, OR WHITE PLASTIC, GRUB SCREW WITH GOLD CENTRE **8p EACH**
 1" DIAM. WITH 1½" SKIRT SPUN ALUMINIUM GRUB SCREW FIXING, ¼" **35p EACH**

ZM1162A INDICATOR TUBE
 0-9 Inline End View, Rectangular Envelope 170V 2.5M/A **£1.50**

REGULATED TAPE MOTOR
 9v d.c. nominal approx 1½" diameter **80p**

12v 8 amp Transformer **£4.00 (p&p 75p)**

Ferric Chloride, Anhydrous mil. spec. 1lb. bag **50p**

TO3 or TO66
 Mica Washer **2p**
 18 volt 4 amp charger, bridge rectifier **50p**
 GC10/4B **£3.00**

Telescopic aerial
 Closed 9½", open 38½"
 Fitted right angle TV plug, **50p**

1 or 2% three times price.
 Semiconductor Data Book 263 pages. Covers 2N21 through to 2N5558 plus some 3N's. Type/connection/parameter details **£1.50**
 No VAT

RESISTORS	
¼ ¼ ½ watt	1p
1 watt	2p
Up to 5 watt wire	10p
10 watt wire wound	12p
15 watt	14p

POTS
 Log or Lin carbon **18p**
 Switched **32p**
 Dual Pots **44p**
 Dual & switch **60p**
 Lin wirewound **25p**
 Slider Pot **40p**
 Dual Slider **52p**
 1.5m Edgetype **8p**

THERMISTORS
 VA1008, VA1034, VA1039, VA1040, VA1055, VA1066, VA1082, VA1100, VA1077, VA1005, VA1026 } **10p**
 VA1077, VA1005, VA1026 } **15p**

RELAYS
 12 volt S.P.C.O octal mercury wetted high speed **75p**
 P.O. 3000 type, 1,000 OHM coil, 4 pole c/o **60p**
 Mains or 12v d.p.c.o heavy duty octal **80p**
 Boxed GEC KT88 valve **£2**

JAP 4 gang min. sealed tuning condensers New **35p**
 Ex-eqpt. 2 or 4 gang **20p**

ELECTROLYTICS MFD/VOLT. Many others in stock
 70- 200- 300- 450-
 Up to 10V 25V 50V 75V 100V 250V 350V 500V MFD

10	4p	5p	6p	8p	10p	12p	16p	20p
25	4p	5p	6p	8p	10p	15p	18p	20p
50	4p	5p	6p	9p	13p	18p	25p	—
100	5p	6p	10p	12p	19p	20p	—	—
250	9p	10p	11p	17p	28p	—	85p	£1
500	10p	11p	17p	24p	45p	—	—	—
1000	13p	22p	40p	75p	—	£1.50	—	—
2000	23p	37p	45p	—	—	—	—	—

As total values are too numerous to list, use this price guide to work out your actual requirements
 8/20, 10/20, 12/20 Tubular tantalum **15p each**
 16-32/275, 32-32/275, 100-100/150, 100-100/275 50-50/300 **20p each**
 50/50-385 **30p**
 12,000/12, 32-32-50/300, 700/200 100-100-100-150-150/320 **50p each**
 20-20-20/350 **40p each**

RS 100-0-100 micro amp null indicator
 Approx. 2" x ¾" x ¾" **£1.50**

INDICATORS
 Bulgin D676 red, takes M.E.S. bulb **30p**
 12 volt or Mains neon, red pushfit **21p**
 R.S. Scale Print, pressure transfer sheet **10p**

CAPACITOR GUIDE - maximum 500V
 Up to .01 ceramic **3p**. Up to .01 poly **4p** Up to 1000PF silver mica **5p**. 1,200PF up to .01 silver mica **10p**. .013 up to .1 poly etc. **6p**.
 .12 up to .68 poly etc. **6p**.
 Over 500 volt order from above guide and few others listed below.
 8p. 1/600: **12p**. .01/1000, 1/350, 8/20, 1/900, .22/900, 4/16, 25/250 AC (600vDC) 1/1500 40p. 5/150, 9/275AC, 10/150, 15/150, 40/150.

TRIMMERS, **20p each**
 100PF Ceramic, 30PF Beehive, 12PF PTFE 2500PF 750 volt, 5 x 50pF, 2 x 220pF, 50PF CERAMIC.

CONNECTOR STRIP
 Belling Lee L1469, 4 way polythene. **6p each**
 1½ glass fuses 250 m/a or 3 amp (box of 12) **24p**
 Bulgin, 5mm Jack plug and switched socket (pair) **30p**

1" or 1½" or 2" or ¾" CAN CLIPS **3p**

MAINS DROPPERS
 36+79 ohm **25p**
 66+66+158 ohm, 66+66+137 ohm
 17+14+6 ohm, 266+14+193 ohm **30p**
 50+40+1k5 ohm
 285+575+148+35 ohm } **40p**
 25+35+97+59+30 ohm

5½" x 2½" Speaker, ex-equipment 3 ohm **30p**
 2 Amp Suppression Choke **7p**
 3 x 2½" x 1½" } PAXOLINE **4p**
 4½" x 1½" x 1½" } **1p**
 PCV or metal clip on MES bulb Holder **5p**
 VALVE RETAINER CLIP, adjustable **2p**

OUTPUT TRANSFORMERS
 Sub-miniature Transistor Type **50p**
 Valve type, centre tapped or straight **40p**

12 volt 250M/A or 6 volt ½ A Transformers **75p**
 Whiteley Stentorian 3 ohm constant impedance volume control way below trade at **80p**
 Drive Cord **2p per yd.**

THE RADIO SHACK

161 ST. JOHNS HILL, BATTERSEA, LONDON S.W.11

Open 10. a.m. till 7 p.m. Monday to Saturday - Also Sunday afternoons

Terms: Payment with order Telephone: 01-223 5016

Full spec. marked by Mullard, etc. Many other types in stock

AC107	20p	BC184C/LC	81p	BD204	£1.00
AC128	71p	BC186	25p	BD232	60p
AC176	9p	BC187	26p	BD234	57p
ACY28	19p	BC213L/214B	10p	BD235	24p
AD149	40p	BC216B	8p	BDX77	£1.40
AD161/2	32p	BC327	8p	BF115	20p
AF116	16p	BC328	12p	BF167/173	22p
AF124	30p	BC337	17p	BF178	26p
AF126	22p	BC338	18p	BF179	30p
AF127	29p	BC547/8/8A	11p	BF180/2/3	28p
AF139	31p	BC557/8/9	12p	BF181	31p
AF178/80/8+	40p	BCX32/36	80p	BF184/5	22p
AF239	34p	BCY40	80p	BF194/5/6/7	7p
ASY27/73	31p	BCY70/1/2	12p	BF194A/195C	10p
BC107A or B	12p	BD112/3/5/6	52p	BF200	25p
BC107/8/9	8p	BD131/2	32p	BF258	24p
BC108A/B/C/109B/C	10p	BD133	54p	BF262/3	50p
BC147/8/9	8p	BD135	21p	BF335	25p
BC148A/B	10p	BD136	26p	BFS28 Dual Mosfet	92p
BC148A/B/C, 9B/C/S	9p	BD137	24p	BFW10 F.E.T.	37p
BC157/8/9	6p	BD139	29p	BFW11 F.E.T.	37p
BC158A/B	12p	BD142	56p	BFW30	£1.35
BC159B/C, 157A	12p	BD201	74p	BFW57/58	20p
BC178A/B/179B	15p	BD202/3	79p	BFX12	20p

Amp	Volt	BRIDGE RECTIFIERS	
1	1,600	BYX10	30p
1	140	OSHO1-200	25p
1.4	42	BY164	47p
0.6	110	EC433	15p
5	400	Texas	75p

RECTIFIERS			
Amp	Volt		
IN4004	1	400	4p
IN4005/6	1	6/800	6p
BY103	1	1,500	15p
SR100	1.5	100	7p
SR400	1.5	400	8p
REC53A	1.5	1,250	14p
LT102	2	30	10p
BYX38-600	2.5	600	65p
BYX38-300R	2.5	300	43p
BYX38-900	2.5	900	60p
BYX38-1200	2.5	1,200	65p
BYX49-600	2.5	600	34p
BYX49-300	2.5	300	26p
BYX49-900	2.5	900	40p
BYX49-1200	2.5	1,200	52p
BYX48-300	6	300	40p
BYX48-600	6	600	50p
BYX48-900	6	900	60p
BYX48-1200	6	1,200	80p
BYX72-150R	10	150	35p
BYX72-300R	10	300	45p
BYX72-500R	10	500	55p
BYX42-300	10	300	30p
BYX42-600	10	600	65p
BYX42-900	10	900	80p
BYX42-1200	10	1,200	95p
BYX46-300*	15	300	£1.00
BYX46-400*	15	400	£1.50
BYX46-500*	15	500	£1.75
BYX46-600*	15	600	£2.00
BYX20-200	25	200	60p
BYX52-300	40	300	£1.75
BYX52-1200	40	1,200	£2.50

*Avalanche type

Amp	Volt	TRIACS	
6	800	Plastic RCA	£1.80
25	900	BTX94-900	£4.00
25	1200	BTX94-1200	£6.00
12-0-12 50M/A Min. Txmfr. 90p			
RS 2mm Terminals Blue & Black 5 for 40p			
Chrome Car Radio fascia 15p			
Rubber Car Radio gasket 5p			
DLI Pal Delayline 50p			
Relay socket 10p			
Take miniature 2PCO relay			
B7G or B9A valve can 6p			
0-30, or 0-15, black pvc, 360° dial, silver digits, self adhesive, 4 1/2" dia. 10p			

OPTO ELECTRONICS			
BPX40	65p	Photo transistor	
BPX42	£1.00	BPX29	£1.00
BPY10	£1.00	OCP71	44p
(VOLIAC)			
BPY68	£1.00	BIG L.E.D. 0.2"	
BPY69		2v 50m/A max.	
BPY77		RED	13p
		ORANGE	19p
		GREEN	15p
		YELLOW	19p
		CLIP	2p
PHOTO SILICON CONTROLLED SWITCH BPX66 PNP 10 amp £1.00			
.3" red 7 segment L.E.D. 14			
D.I.L. 0-9 + D.P. display 1.9v, 10m/a segment, common anode 75p, DL747.6 £1.75			
CQY11B L.E.D. Infra red transmitter £1 One fifth of trade			
Plastic, Transistor or Diode Holder 1p			
Transistor or Diode Pad 1p			
Holders or pads 50p per 100			
Philips Iron Thermostat 15p			
Bulgin 2-pin flat plug socket 10p			
McMurdo PP108 8 way edge plug 10p			
TO3 HEAT SINK			
Europlec HP1 TO3B individual 'curly' power transistor type. Ready drilled 20p			

TESTED UNMARKED, OR MARKED AMPLE LEAD EX NEW EQUIPMENT			
ACY17-20	8p	OC71/2	5p
ASZ20	8p	OC200-5	10p
ASZ21	30p	TIC44	24p
BC186	11p	2G240	2-50
BCY30-34	10p	2G302	10p
BCY70/1/2	8p	2G401	15p
BF115	10p	2N711	25p
BY127	9p	2N2926	7p
		2N598/9	6p
		2N1091	8p
HG5009	3p	2N1302	8p
HG5079	3p	2N1907	2-50
L78/9	3p	Germ. diode	1p
M3	10p	GET120 (AC128 in 1" sq. heat sink)	
OA81	3p	GET872	25p
OA47	3p	2S3230	30p
OA200-2	3p		
OC23	20p		

OTHER DIODES			
1N916	8p		
1N4148	5p		
BA145/148	15p		
Centercel	10p		
BZY61	10p		
BB103/110 Varicap	23p		
BB113 Triple Varicap	37p		
BA182	13p		
OA5/7/10	14p		
BZY88 Up to 33 volt	61p		
BZX61 11 volt	17p		
BR110 Diac	20p		

INTEGRATED CIRCUITS			
TAA700	£3.80		
723 reg (TO99)	45p		
741 8 pin d.i.l. op. Amp	181p		
TAD100 AMRF	£1.30		
CA3001 R.F. Amp	50p		
TAA300 1vt Amp	£1.84		
NE555v Timer	321p		
TAA550 Y or G	32p		
TAA263 Amp	65p		
7400/10	9p		
7402/4/20/30	11p		
7414	45p		
7438	74p		
7438/74/86	24p		
LM300, 2-20 volt	£1.50		
74154	£1.11		

THYRISTORS			
1	240	BTX18-200	35p
1	400	BTX18-300	40p
1	240	BTX30-200	35p
15	500	BT107	£1.00
6.5	500	BT101-500R	90p
6.5	500	BT109-500R	75p
20	600	BTW92-600RM	£3.00
15	800	BTX95-800R Pulse Modulated	£8.00
30	1000	2BT10 (Less Nut)	£3.00

PAPER BLOCK CONDENSER			
0.25MFD	800 volt	30p	
1MFD	250 volt	15p	
2MFD	250 volt	20p	
10MFD	500 volt	80p	
4MFD	250 volt	20p	

METAL CHASSIS SOCKETS			
Car Aerial Coax			
5 or 6 pin 240° din			9p
Speaker din switched			
3.5mm Switched Socket			
8 way Cinch standard			
0.15 pitch edge socket			20p
U.E.C.L. 10 way pin connector 2B6000			
OA1P10			10p
U.E.C.L. 20 way pin connector			
2A60000A1P20			20p
U.E.C.L. 10 way pin socket 2B606001R10			10p
U.E.C.L. 20 way pin socket 2B60800A1R20			20p
3.5mm STEREO PLUG			
Metal screened			35p
Philips electronic engineer kits add on series			
E1004			£1.00 each
RS Yellow Wander Plug Box of 12			25p

THYRISTORS			
1	240	BTX18-200	35p
1	400	BTX18-300	40p
1	240	BTX30-200	35p
15	500	BT107	£1.00
6.5	500	BT101-500R	90p
6.5	500	BT109-500R	75p
20	600	BTW92-600RM	£3.00
15	800	BTX95-800R Pulse Modulated	£8.00
30	1000	2BT10 (Less Nut)	£3.00

GARRARD			
GCS23T or GP93/1			
Crystal Stereo Cart-ridge			£1.00

HANDLES			
Rigid light blue nylon 6 1/2" with secret fitting screws			8p
Belling Lee white plastic surface coax outlet box			35p
Miniature Axial Lead Ferrite Choke formers			2p
RS 10 Turn Pot 1% 250, 500 Ω; 1, 50, 100K			£1.50
Copper coated board 10" x 9" approx.			40p

TIE CLIPS			
Nylon self locking 7" or 3 1/2"			2p
Geared Knob 8-1 ratio 1 1/8" diam, black			70p
1lb Mixed bolts, nuts, washers etc.			45p

SMALL ORDERS, ENCLOSE SUITABLE STAMPED ADDRESSED ENVELOPE. LARGE ORDERS, ADD SUFFICIENT FOR POSTAGE, INSURANCE, ETC. TOTAL GOODS PLUS CARRIAGE, ADD V.A.T.

MAIL ORDER CUSTOMERS ONLY ADD 8% VAT-I PAY BALANCE ON 2 1/2% ITEMS ALL ENQUIRIES, ETC., MUST BE ACCOMPANIED BY A STAMPED ADDRESSED ENVELOPE

DESIGNED BY TEXAS



**30,000
ALREADY
SOLD**

**Texan Amplifier
as featured by
PRACTICAL WIRELESS
SOLE U.K. DISTRIBUTORS - HENRY'S**

Build it yourself for only

£32 KIT PRICE inc. VAT + £1.00 p&p
Built and tested £42.00 inc. VAT + £1.00 p&p

Build the Texan stereo amplifier, then you can be doubly proud! For a start, you'll own a superb home entertainment unit. And have had all the pleasure of doing it yourself, with the Henry's kit.

Look at the Texan specification

Incorporating fully integrated stereo preamp and power amp, with 6 IC's, 10 transistors, 6 rectifiers and zener diodes. Plus stabilised, protected circuitry, glass lib pcb. Gardeners low-field low-line mains transformer, all facilities and controls. Slim design, chassis 14" x 8" x 2" overall. 20 watts per channel RMS, less than 0.1% distortion at 1 kHz.

★ Can be built Stage by stage
★ Ask for leaflets 5.
★ Everything necessary supplied.
★ Full after sales service and guarantees.

TEXAN FM TUNER KIT **£23.50**
inc. VAT + 50p p&p

Built and tested £28.50 inc. VAT + 50p p&p.

Build the matching Texan stereo tuner! Features advanced varicap tuning. Phase lock loop decoder. Professionally designed circuit. Everything you need is in the kit. From the glass fibre pcb to the cabinet itself. Excellent spec: 2.5 uV aerial sensitivity. 500 mV output (adjustable). Tuning range 87-102 MHz. Mains powered.

THE NATURAL FOLLOW-ON

Henry's latest ELECTRONICS CATALOGUE

- * over 5000 items - many new
- * free 50p voucher inside every copy
- * virtually everything needed by amateurs and professionals
- * over 200 pages
- * easy-to-use, complete alphabetical index
- * section index
- * everything at competitive prices

FREE to Educational Establishments when ordered on official headed notepaper + 20p carr. / pack

VIDEO SPORT



An up-to-the-minute game. Plugs into your own TV aerial socket. Switch on. And you're away! Choose your game - football, tennis or hole-in-the-wall. Absolutely safe. For you. Your children. And your TV. Mains powered. List Price £42.50.

HENRY'S PRICE
£25.00
inc. VAT + 50p p&p
★ OVER 10,000 ALREADY SOLD
★ IDEAL GIFT

For this latest edition, we have made hundreds of changes and additions. Features now include:



HENRY'S RADIO

All mail to: Henry's Radio
303 Edgware Rd. London W2

- LONDON W2: 404/6 Edgware Road. Tel: 01-402 8381
LONDON W1: 231 Tottenham Ct Rd. (lower sales floor) Tel: 01-636 6681
* NOTTINGHAM: 94/96 Upper Parliament St. Tel: (0602) 40403
* READING, BERKS: 130/131 Friar Street. Tel: (0734) 583230
* HARROW: 190/4 Station Road. Tel: 01-863 7788
* CROYDON: 110 North End. Tel: 01-681 3310

*** NEW STORES**

Please Note: Mail Order Customers HENRY'S WILL CREDIT ANY VAT OVERPAYMENTS
VAT DOWN

Sparkrite mk2

Capacitive discharge
electronic ignition kit

**VOTED BEST
OF 8 SYSTEMS
TESTED BY
'POPULAR
MOTORING'
MAGAZINE**



- * Smoother running
- * Instant all-weather starting
- * Continual peak performance
- * Longer coil/battery/plug life
- * Improved acceleration/top speeds
- * Up to 20% better fuel consumption

Sparkrite Mk. 2 is a high performance, high quality capacitive discharge, electronic ignition system in kit form. Tried, tested, proven, reliable and complete. It can be assembled in two or three hours and fitted in 15/30 mins.

Because of the superb design of the Sparkrite circuit it completely eliminates problems of the contact breaker. There is no misfire due to contact breaker bounce which is eliminated electronically by a pulse suppression circuit which prevents the unit firing if the points bounce open at high R.P.M. Contact breaker burn is eliminated by reducing the current to about 1/50th of the norm. It will perform equally well with new, old, or even badly pitted points and is not dependent upon the dwell time of the contact breakers for recharging the system. Sparkrite incorporates a short circuit protected inverter which eliminates the problems of SCR lock on and, therefore, eliminates the possibility of blowing the transistors or the SCR. (Most capacitive discharge ignitions are not completely foolproof in this respect). All kits fit vehicles with coil/distributor ignition up to 8 cylinders.

THE KIT COMPRISES EVERYTHING NEEDED

Ready drilled pressed steel case coated in matt black epoxy resin. ready drilled base and heat-sink, top quality 5 year guaranteed transformer and components, cables, coil connectors, printed circuit board, nuts, bolts, silicon grease, full instructions to make the kit negative or positive earth, and 10 page installation instructions.

OPTIONAL EXTRAS

Electronic/conventional ignition switch. Gives instant changeover from "Sparkrite" ignition to conventional ignition for performance comparisons, static timing etc., and will also switch the ignition off completely as a security device, includes: switch connectors, mounting bracket and instructions. Cables excluded. Also available RPM limiting control for dashboard mounting (fitted in case on ready built unit).

CALLERS WELCOME. For Crypton tuning and fitting service - phone (0922) 33008.

PRICES INCLUDE VAT, POST AND PACKING.

Improve performance & economy NOW

POST TODAY!

Quick installation
No engine modification
required

Electronics Design Associates, Dept., REC/7
82 Bath Street, Walsall, WS1 3DE. Phone: (0922) 33652

Name
Address

Mk. 2 DIY Ass. Kit @ £11.80	QUANTITY REQD.
Mk. 2 Ready Built Negative Earth @ £14.97	
Mk. 2 Ready Built Positive Earth @ £14.97	
Ignition Changeover switches @ £4.30	
R.P.M. Limit systems in above units @ £2.42	

I enclose cheque/PO's for **£**
Cheque No.
Send SAE if brochure only required.

PRECISION PETITE LTD

119a High Street
Teddington, Middx.

Tel: 01-977 0878

Have pleasure in introducing
their Precision Tools from
France for all types of
electronic design and
development, professional
or amateur



THE ABOVE KIT IS AVAILABLE AS SEPARATES

	£ p	p&p
● Kit Complete as above	30.50	1.15
● Mk.II Drill Stand	4.00	35
● Mk.II Drill Only	8.00	35
● Flexible Shaft.....	5.00	25
● Transformer	5.50	70
● S.30 Kit (30 tools).....	16.00	85
● S.10 Kit (10 tools).....	12.50	65

(Any Quantity)

Replacement accessories	40p each	15p
Circular Saw Blade Sets (4)	£2.40	15p
Spare Collets.....	£0.40	15p
Spare Chuck & 3 Collets	£2.50	15p

ALL ABOVE PRICES INCLUDE V.A.T.

S.A.E. FOR ILLUSTRATED LEAFLET
& ORDER FORM

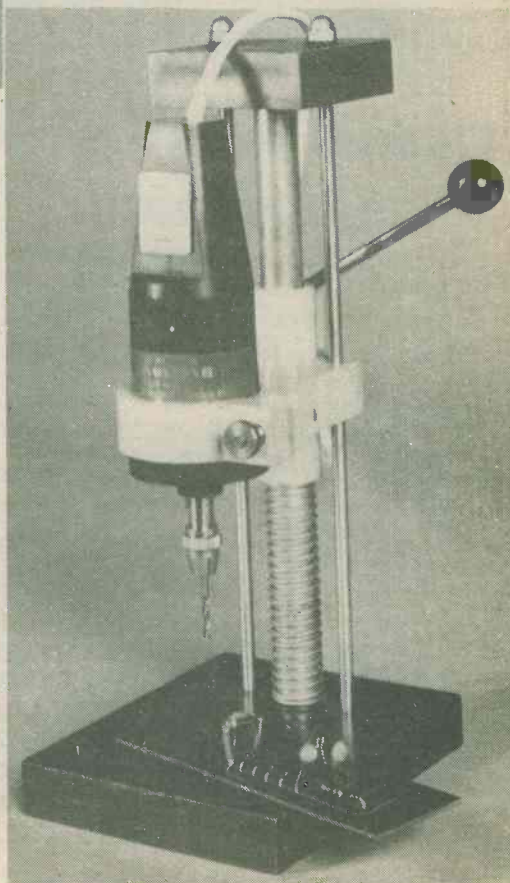

Random FLASHER UNIT



Wired ready for use Complete with three 100 watt coloured lamps that flash independently at random

£18.95

TWIN BANK 6 LIGHT UNIT
(less lamps) LENGTH 14 1/2 inches



B.C. Fitting **£9.55** EACH
E.S. Fitting **£10.35** EACH

Sound to Light MASTER UNIT



600 WATTS PER CHANNEL

£30.95

INCLUDING CHANNEL OUTPUT PLUGS AND MAINS INPUT SOCKET

TYPE A SPOT
(less lamp)



B.C. Fitting **£1.95** EACH | E.S. Fitting **£2.12** EACH

TYPE B 3 BANK UNIT
(Less Lamps)



B.C. Fitting **£6.90** EACH | E.S. Fitting **£7.26** EACH

TWIN BANK 12 LIGHT UNIT
Length 31 3/4



(less lamps)

B.C. Fitting **£15.60** EACH | E.S. Fitting **£17.00** EACH

100 WATT SPOT LAMPS
RED, YELLOW, GREEN
BLUE, CLEAR

Maximum 3 lamps

£1.18 each | **£3.54**

B.C. or E.S. Fitting

ALL PRICES INCLUDE V.A.T. and POST & PACKING (These prices apply to the United Kingdom only)

ALBEN ENGINEERING CO. LTD.
DEPT. RE THE CRESCENT, WORSTHORNE,
BURNLEY, LANCS. Tel: Burnley 20940

ELECTROVALUE

the good components service

In relatively few years, Electrovalue has risen to a position of pre-eminence as mail-order (and industrial) suppliers of semi-conductors, components, accessories, etc. There are wide ranges and large stocks to choose from as well as many worthwhile advantages to enjoy when you order from Electrovalue.

Orders may be made using Access or Barclaycard.

CATALOGUE 8 ISSUE 2

Second printing now ready, revised and up-dated on prices, etc. 144 pages. New items, Opto-electronics, Diagrams of components, applications, I.C. circuits, etc. Post free 40p, including voucher for 40p for spending on order over £5 list value.

DISCOUNTS

On all C.W.O. mail orders, except for some items marked NETT.
5% on orders list value | 10% on orders list value
£10 or more | £15 or more
Not allowable on credit-card purchases

FREE POST & PACKING

On all C.W.O. mail orders in U.K. over £2 list value. If under, add 15p handling charge.

PRICE STABILIZATION POLICY

Prices are held and then reviewed over minimum periods of 3 months next review due October 1st.

QUALITY GUARANTEE

On everything in our Catalogue — No manufacturer's rejects, seconds or sub-standards merchandise.

ELECTROVALUE LTD

All communications to: Section 6/7 28, ST. JUDE'S ROAD, ENGLEFIELD GREEN, EGHAM, SURREY TW20 0HB. Telephone Egham 3603, Telex 284475. Shop hours 9-5.30 daily; 9-1 pm Sats.
NORTHERN BRANCH: 680, Burnage Lane, Burnage, Manchester M19 1NA. Telephone (0611) 432 4945. Shop hours Daily 9-5.30 pm, 9-1 pm Sats.

1. Understand electronics.

Step by step, we take you through all the fundamentals of electronics and show you how easily the subject can be mastered using our unique Lerna-Kit course.

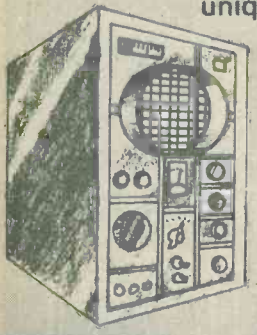

- (1) Build an oscilloscope.
- (2) Read, draw and understand circuit diagrams.
- (3) Carry out over 40 experiments on basic electronic circuits and see how they work.

2. Become a radio amateur.

Learn how to become a radio-amateur in contact with the whole world. We give skilled preparation for the G.P.O. licence.

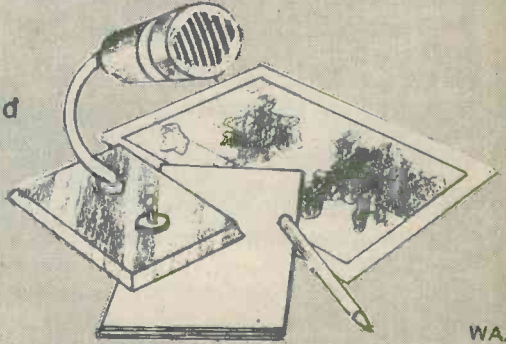

Free!

Brochure, without obligation to:
BRITISH NATIONAL RADIO & ELECTRONICS SCHOOL, Dept. REX 76
P.O. Box 156, Jersey, Channel Islands.

NAME _____

ADDRESS _____ Block caps please

BI-PRE-PAK

Bargains in Semi-Conductors, components, modules & equipment.

B-P-P Packs

Originated in 1959 by managing director Bernard Davis, his were the first semi-conductor and component packs to be marketed in this country, and indeed, the company's name grew out of "British Industrial Pre-Packaged Components". Today, Bi-Pre-Pak continues to occupy a position of pre-eminence in the supply of packs as well as a vastly extended range of products detailed in our latest 24 page A4 size free catalogue. Send 10p large s.a.e. for your copy by return. Plus special summer bargains list.

IT'S ALL IN OUR FREE CATALOGUE

Component Packs

CP1 150 Capacitors, mixed bag of paper, silver mica, electrolytics, etc. Approx quantity, counted by weight.....60p
 CP2 200 Resistors, mixed bag of different types, values, wattages, etc. Approx. quantity, counted by weight.....60p
 CP3 40 Wirewound resistors, mixed types, values and wattages.....60p
 CP4 12 Potentiometers, pre-sets, w/wound, carbon, etc. Mixed types and values.....60p
 CP5 5 Earphones, single low impedance for transistor radio cassettes, etc. Less plugs, for suitable plugs see PAKs CP9 and CP10.....60p
 CP6 50 TO-5 mounting pads, fits between transistor and board for that pro. finish.....60p
 CP7 5 2.5mm sub miniature jack, to fit earphones in PAK CP5.....60p
 CP8 500 Cable clips for G.P.O. 1/2" dia. cable Nylon with hardened steel pin (probably tungsten) per sealed box of 500.....60p
 CP9 5 3-5mm plugs, miniature jack, to fit earphones in PAK CP5.....60p
 CP10 5 2.5mm sub miniature jack, to fit earphones in PAK CP5.....60p
 CP11 6 Screwdrivers, 1 x mains neon tester, 5 x grub screwdrivers.....60p
 CP12 10 Reed relay inserts, 1" long 1/2" dia. These will operate from an external magnet or coil. For magnets see PAK CP13.....60p
 CP13 10 magnets of various sizes for operating reedswitches in PAK CP12. Ideal for burglar alarms on doors and windows, etc.....60p
 CP14 40 Potentiometers, pre-sets, carbons, dualgangs, with and without switches etc. Mixed values and wattages £1.20
 CP15 12 Standard crocodile clips, screw fixing, good quality.....60p
 CP16 5 P.C. boards each containing a BF180 UHF amplifier transistor. A good basis for building a T.V. aerial pre-amp as various parts inc.....60p
 CP17 25 Electrolytic Capacitors, various values and voltages, many useful types, from T.V. to transistor radio and Hi-Fi (post and packing 23p).....60p
 CP18 1 Light activated SCR.50 volts 1.6 amps type 19F. Ready mounted on PC board with gate resistor and leads fitted. Full data and circuit diagrams for 14 projects. Includes: slave photo flash unit, burglar alarm, etc.....60p
 CP19 3 Micro switches 1 pole change over, standard model 1" x 1".....60p
 CP20 10 Relays, assorted types, ex-GPO and others, mixed voltages.....£1.20
 CP21 200 Square inches of copper laminate P.C. board, in approx. 8 pieces.....60p
 CP22 3 Fibreglass plain printed circuit boards, approx 2 1/2" x 14".....60p
 CP23 4 Switches, miniature push to make single pole 60p

Semi-Conductors

TESTED AND GUARANTEED

TP4 3 SN7490 integrated circuits, 14 pin dual in line TTL type. Decade counter. Get one FREE these are 60p each in singles.....£1.20*

ALL THE FOLLOWING ARE AT 60p EACH PACK

TP9* 5 SN7400 integrated circuits, 14 pin dual in line TTL type. Quad 2-input NAND gate. Get one FREE, these are 15p each.
 TP10 2 light dependant resistors. 400 ohms light, 1 megohm dark. 1/2" dia.
 TP11 10 Transistors XB102 and XB112 equiv. to AC126, AC156, OC81/2, OC72, etc.
 TP12* 4 BY127 Silicon rectifiers 1000 pIV amp. Plastic TV rectifier.
 TP13* 5 OCP71 Light sensitive transistors.
 TP14 20 OC71 germanium PNP audio pre-amp transistor, black glass type.
 TP15 20 OC81 germanium PNP audio output transistor, white glass type.
 TP18 20 OC200/1/2/3 transistors, PNP silicon TO-5, unmarked.
 TP17 20 1 watt zener diodes, mixed voltages, 6-8 to 43 volts.
 TP18 20 2N3707/8/9/10 transistors, NPN silicon plastic, unmarked.
 TP19 100 Diodes, mixture of germanium, gold-bonded, silicon, etc. a useful selection of many types, marked and unmarked.
 TP20 10 Mullard OC45 transistors, I.F. amp. PNP germanium.
 TP23 20 8FY501/1/2, 2N636/7, 2N1613, etc. NPN silicon TO-5 unceded. Complementary to PAK TP24.
 TP24 20 8FY64, 2N2904/5, etc. PNP silicon TO-5 unceded. Complementary to PAK TP23.
 TP30 20 NPN silicon planar transistors, TO-18 similar to BC108 etc. unceded.
 TP31 20 PNP silicon planar transistors, TO-18 similar to BC178 etc. unceded.
 TP32 20 2N2926 silicon plastic transistors, unceded and ungraded for colours.

UNTESTED PACKS - 60p EACH
 Specially for keen bargain hunters

UT1 50 PNP germanium transistors, AF and RF. Very good yield.
 UT2 150 Germanium diodes, miniature glass type.
 UT6 40 Zener diodes, 250 mW OA7240 range, average 50% good.

SINGLES

Bridge Rectifiers, Plastic encapsulated
 P1V 1 amp 50v 100v 400v
 1 amp 25p 35p 45p
 2 amp 35p 45p 55p
 4 amp 45p 50p 80p
 6 amp 50p 60p 90p
 BY164 equiv. SKB2/02 400v 1.5 amp.....45p

F.E.T.s:
 2N3913 18p; 2N4416 20p
 Mos F.E.T.s:
 3N141/MEM616.....50p
 Uni-Junction Transistors:
 2N2160 65p; 2N2646 48p
 TIS 43 31p
 P.U.T.s: 2N2602.....50p
 L.E.D.s: TIL209, Red.....18p
 TIL211, Green.....33p

Also:
 POWER DIODES,
 THYRISTORS,
 TRIACS,
 DIAC,
 ZENER DIODES,
 OPTO-ELECTRONICS,
 Etc.

X-44 POCKET SIZE R.F. CROSS HATCH GENERATOR

Size 150 x 75 x 50mm, strong plastic case with handle/stand 4 push button operation, 4 patterns. Self-contained line and frame generator and synchro pulse. Pre-set adjust for R.F. output and line/frame synch. Uses 4 alkaline type 1800 batts. Blank raster facility FOR COLOUR AND MONO. (P/P add 35p) Burnt & tested

£27.50

POWER TRANSISTORS

	Vcc	Watts	1c Amps	Price
40P1	15	20	3	20p*
40N2	40	40	4	30p*
40P2	40	40	4	30p*
90N1	15	45	4	25p*
90P1	15	45	4	25p*
90N2	40	90	8	35p*
90P2	40	90	8	35p*

Many other types available from 3 to 115 watts

Integrated Circuits: MM5314 Dual in line clock chip £3.00
 LM 3800/SL 60745 Dual in line 2w audio amp. with data, etc.....75p
 Dual in line IC sockets 8 pin - 14p; 14-pin - 16p*; 16-pin - 16p*

Sundry

Signal Generator: For MW and IF covers 550 KHz to 1.6 MHz for MW and 400 to 550 KHz for IF. Fully portable (p&p £4.25)
 Pocket Signal Injector: Fountain-pen type, invaluable for finding faults.....£2.00*
 Ex-GPO 5" Sidecutters: Not new, but in perfect order, per pair.....50p*
 Ex-GPO 6" Long Nose Pliers: Not new, but in perfect order, per pair.....60p*
 Mains Transformers:
 MT6 6v 0 6v 100mA.....£1.22*
 MT12 12v 0 12v 50mA.....£1.22*
 SST9/1 9v 1amp.....£1.67*
 SST12/1 12v 1amp.....£2.05*
 SST18/1 18v 1amp.....£2.50*
 SST25/2 25v 2amp.....£3.00*
 SST30/2 30v 2amp.....£4.25*
 SST35/4 35v 4amp.....£5.50*

PC EDGE CONNECTORS

Type	Size	Pitch	Price
SSEC 6 way	1 1/2"	.156"	32p
SSEC 10 way	1 1/2"	.156"	60p
SSEC 12 way	1 1/2"	.156"	60p
SSEC 16 way	2 1/2"	.156"	75p
SSEC 18 way	3"	.156"	85p
SSEC 22 way	3 1/2"	.156"	100p

SPECIAL OFFER - F.M. STEREO DECODERS
 I.C. unit, for negative earth, with data.....£1.95
 Stereotised version, pos. earth, with data.....£1.75
 RADIO CHASSIS ON PCB'S (No speakers, no guarantee). Useful for experimenting, components etc. A.M. 75p; AM/FM £1.00

BOOKS

All free of VAT - We carry very large stocks of technical books by Babani & Bernard Publishers, by Newnes and Butterworth as well as reference books from the Common Market in English / German / Italian. All detailed in our catalogue.

B-P-P SECURITY CHECK POINT

- Write your own name and address clearly in block capital letters.
- Check that your order is correct for description, quantity and price.
- Don't forget V.A.T. at 12 1/2% of total value of order unless otherwise stated.
- MAKE SURE YOU GET OUR NAME AND ADDRESS RIGHT WHEN ORDERING
- Cash (cheque, money or postal order) with your order, please.
- Mention this journal when ordering if you don't want to cut out the coupon.

TERMS OF BUSINESS:

12 1/2% VAT must be added to total value of order except for items marked (B) when VAT is to be added at 8%. No VAT on overseas orders. POST & PACKING add 30p for UK orders unless marked otherwise. Minimum mail order acceptable - £1. Overseas orders, add £1 for postage. Any difference will be credited or charged. PRICES subject to alteration, without notice. AVAILABILITY: All items available at time of going to press when every effort is made to ensure correctness of information.

To BI-PRE-PAK, 224-226 WEST RD., WESTCLIFF-ON-SEA, ESSEX

Please send..... inc. V.A.T.

for which I enclose.....

Name.....

Address.....

REC. 7A



BI-PRE-PAK LTD

Co. Reg. No. 8201919

222 224 WEST ROAD, WESTCLIFF-ON-SEA, ESSEX SSO 9DF.

TELEPHONE: SOUTHDEN (0702) 46344.

WRITE ORDER SEPARATELY AND ATTACH COUPON IF REQUIRED

THE MODERN BOOK CO

R.S.G.B. VHF - UHF MANUAL

by D. S. Evans and G. R. Jessop

PRICE: £5.60

FOUNDATIONS OF WIRELESS & ELECTRONICS
by M. G. Scroggie PRICE: £4.25

ELECTRONICS & RADIO
by M. Nelkon PRICE: £3.00

MAKING & REPAIRING TRANSISTOR RADIOS
by W. Oliver PRICE: £2.10

BEGINNER'S GUIDE TO TRANSISTORS
by J. A. Reddihough PRICE: £2.50

PRINTED CIRCUIT ASSEMBLY
by M. J. Hughes PRICE: £2.00

110 SEMICONDUCTOR PROJECTS FOR THE
HOME CONSTRUCTOR by R. M. Marston PRICE: £2.70

ELECTRONIC COMPONENTS
by M. A. Colwell PRICE: £2.00

110 THYRISTOR PROJECTS USING SCRS &
TRIACS by R. M. Marston PRICE: £2.70

ELECTRONIC DIAGRAMS
by M. A. Colwell PRICE: £2.00

PRACTICAL CIRCUIT DESIGN FOR THE
EXPERIMENTER by D. Tuite PRICE: £2.55

HOW TO USE INTEGRATED CIRCUIT LOGIC
ELEMENTS by J. W. Streater PRICE: £3.00

ELECTRONICS POCKET BOOK
by P. J. McGoldrick PRICE: £4.20

MAKING YOUR OWN ELECTRONIC GADGETS
A BEGINNER'S GUIDE by R. H. Warring PRICE: £2.50

SERVICING WITH THE OSCILLOSCOPE
by G. J. King PRICE: £5.00

TRANSISTOR AUDIO & RADIO CIRCUITS
by Mullard PRICE: £3.00

RADIO CONSTRUCTION FOR AMATEURS
by R. H. Warring PRICE: £2.70

BEGINNER'S GUIDE TO TELEVISION
by G. J. King PRICE: £2.50

ABC OF HI-FI
by J. Earl PRICE: £4.05

RADIO SERVICING POCKET BOOK
by V. Chapel PRICE: £2.75

RADIO & AUDIO SERVICING HANDBOOK
by G. J. King PRICE: £4.75

THE AUDIO HANDBOOK
by G. J. King PRICE: £6.00

TEST EQUIPMENT FOR THE RADIO AMATEUR
by H. L. Gibson PRICE: £2.25

PRICES INCLUDE POSTAGE

We have the Finest Selection of English and American Radio Books in the Country
19-21 PRAED STREET (Dept RC) LONDON W2 1NP
Telephone 01-723 4185

NEW STYLE SELF-BINDER

for
"Radio & Electronics
Constructor"



The "CORDEX" Patent Self-Binding Case will keep your issues in mint condition. Copies can be inserted or removed with the greatest of ease. Rich maroon finish, gold lettering on spine.

Specially constructed Binding Cords are made from Super Linen of great strength, very hard twisted and twice doubled. They are attached to strong RUSTLESS Springs under tension, and the method adopted ensures PERMANENT RESILIENCE of the Cords. Any slack that may develop is immediately compensated for and the Cords will always remain taut and strong. It is impossible to overstretch the springs, as a safety check device is fitted to each.

PRICE
£1.00

including V.A.T.

P. & P. 25p

Available only from:—

Data Publications Ltd. 57 Maida Vale London W9 1SN

I'M NEW TO THIS GAME, BUT....



... my grandfather bought his first bits and pieces from Home Radio of Mitcham 30 years ago — and he still relies on them! So does my father. It's not surprising that I've been bitten by the same bug.

When Dad saw how keen I was on electronic gadgets he bought me a Home Radio Components catalogue. Between you and me I think he was getting fed up with me borrowing his! I must say it really is a smashing book. I spend hours poring over it deciding what I shall save up for next. Although I can't afford to spend much yet Home Radio treat me like a millionaire. I've been told that it's a small family business that hasn't grown too big to care for the amateur constructor.

Another thing I like about Home Radio is that if I have any queries or problems I can go right to the man at the top. On several occasions I've found him jolly helpful.

Let me tell you a bit more about this catalogue. It lists about 5,000 items and has about 2,000 pictures (so they tell me — I haven't actually counted them) and it's laid out so clearly that even I can find my way around it easily. It also tells you all about their Deposit Credit Scheme which I will be able to join as soon as I'm eighteen. I find it quite exciting to think that I shall then be able to pick up the phone on a Sunday night and read over my order to their answerphone machine, and by Monday my gear will be on its way to me. I can hardly wait!

Please write your Name and Address in block capitals

NAME

ADDRESS

.....

.....

HOME RADIO (Components) LTD., Dept. RC
234-240 London Road, Mitcham, Surrey CR4 3HD
Regd. No. 912966, London



POST THIS COUPON
with cheque
or p.o. for
£1.25

The price of £1.25 applies only to customers in the U.K. and to BFPO Addresses.

If you are a constructor, of any age between nine and ninety, you really must get a copy of the fabulous Home Radio Catalogue. The cost is only 90 pence, plus 35 pence for postage and packing. Why not send them a cheque or postal order for £1.25 today?

HOME RADIO (Components) LTD. Dept. RC. 234-240 London Road, Mitcham. CR4 3HD. Phone: 01-648 8422

GENERAL PURPOSE I.C. AMPLIFIER

by
F. G. Rayer

This simple a.f. amplifier requires only a small number of discrete components in addition to its integrated circuit.

This is a simple mains operated a.f. amplifier which provides over 0.5 watt output and which requires few components. It will be found very useful in conjunction with a tuner or with any other signal source of similar level, and construction involves few problems. The input signal voltage should be of the order of 100mV or more.

The complete circuit appears in Fig. 1 and it will be seen that it incorporates an LM380N integrated circuit, which needs few peripheral components. VR1 is the input volume control. R1 and C2 form a Zobel network which compensates for the fact that the speaker does not present a truly resistive load. A 3½ in. speaker is fitted in the amplifier case, to produce a single compact unit.

Mains transformer T1, the two rectifiers D1 and D2, and reservoir capacitor C3 provide a full-wave rectified supply for the amplifier. The speaker specified has an impedance of 16Ω. Speakers with lower impedances must not be used unless a mains transformer offering a higher secondary current than that used in the prototype is employed. This point is discussed in greater detail at the end of the article.

The mains transformer has a centre-tapped secondary rated at 12-0-12 volts, 100mA. The transformer employed in the author's amplifier was obtained from Home Radio.

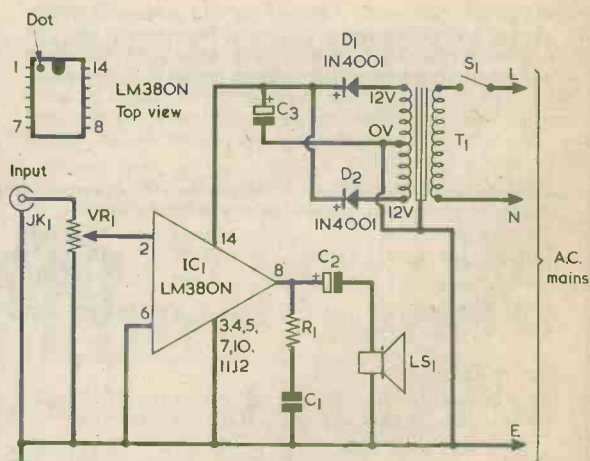
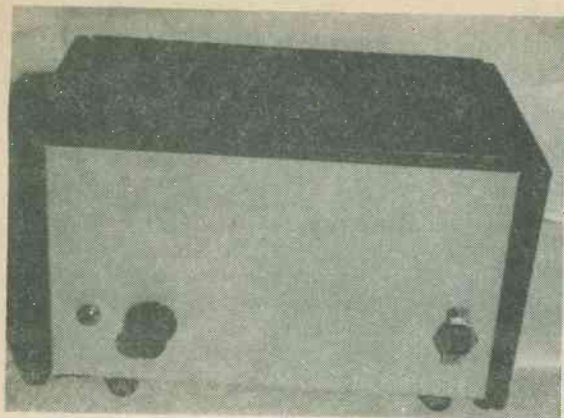

Fig. 1. The general purpose amplifier has the very simple circuit shown here



The front of the amplifier. The front panel, behind which is mounted the speaker, is covered overall with fabric

COMPONENTS

Resistors

- R1 2.7 Ω $\frac{1}{4}$ watt 10%
- VR1 50k Ω potentiometer, log

Capacitors

- C1 0.1 μ F plastic foil
- C2 500 μ F electrolytic, 15 V. Wkg.
- C3 2,500 μ F electrolytic, 25 V. Wkg.

Transformer

- T1 Mains transformer, secondary 12-0-12V at 100mA (see text)

Semiconductors

- IC1 LM380N
- D1 1N4001
- D2 1N4001

Switch

- S1 s.p.s.t. toggle

Socket

- JK1 3.5mm. jack socket

Speaker

- LS1 16 Ω speaker, 3 $\frac{1}{2}$ in. round (see text)

Materials for Case

- 2-off Universal Chassis sides, 7 x 4in. (Home Radio)
- 1-off Universal Chassis plate, 7 x 4in. (Home Radio)
- 2-off 6mm. plywood pieces, 4 $\frac{1}{2}$ x 4 $\frac{1}{2}$ in.
- 1-off 6mm. plywood piece, 7 x 4 $\frac{1}{2}$ in.

Miscellaneous

- Veroboard, 0.1in. matrix, 30 holes by 25 strips
- 14-way i.c. socket (if required)
- 3-way tagstrip, centre tag earthed
- Knob
- Fabric
- 4 rubber feet
- 3-core mains lead
- Screened wire
- Nuts, bolts, etc.

VEROBOARD PANEL

The components, including the mains transformer, are assembled on a piece of 0.1 in. Veroboard having 30 holes by 25 copper strips. The underside of this board is shown in Fig. 2. Three 6BA clear mounting holes are drilled as shown, and it will be noted that the strips adjacent to the two upper holes in the diagram are cut to isolate the holes from the strip sections to which are connected the speaker and the positive lead-outs of the rectifiers and C3. The lowermost strip in the diagram does not need to be isolated in this manner, and it allows the negative rail of the supply to connect to chassis via the board mounting arrangements.

Two further 6BA clear holes for mounting the mains transformer, above the board, are also drilled. The heads of the 6BA bolts appear in the diagram, and their positions correspond with the transformer used in the prototype. One of the strips adjacent to the upper bolt head is cut, to isolate the strip section to which the negative lead-out of D1 connects. The lower bolt head may be in contact with the second strip from the bottom, which is at chassis potential, and this is in order. If it is found that the transformer mounting centres require the upper bolt head to be at a slightly different position, isolate the adjacent strips by cutting them if there is any risk of the bolt head making contact with circuit connections.

Two link wires above the board are shown in broken line. One connects pin 14 of the i.c. to the positive supply point, and the other connects pin 3 of the i.c. to the negative supply line, Pins 3, 4, 5, 6 and 7 are most easily connected together by a link wire soldered on the copper side of the board, as in the diagram. The resistor, the three capacitors and the two rectifiers are all mounted above the board with their lead-outs connecting to the points indicated.

The top view of the integrated circuit is shown inset in Fig. 1. A dot identifies pin 1, and there may also be an indent at this end of the i.c. body. The i.c. may be soldered directly to the Veroboard in the position indicated in Fig. 2. Alternatively, a 14 way d.i.l. integrated circuit holder may be soldered to the board and the i.c. plugged into this.

Two flexible insulated wires are soldered to the board at the points indicated for the speaker. An input screened lead, with the braiding connecting to pin 3 of the i.c., is also soldered on. These wires are cut to their final length later.

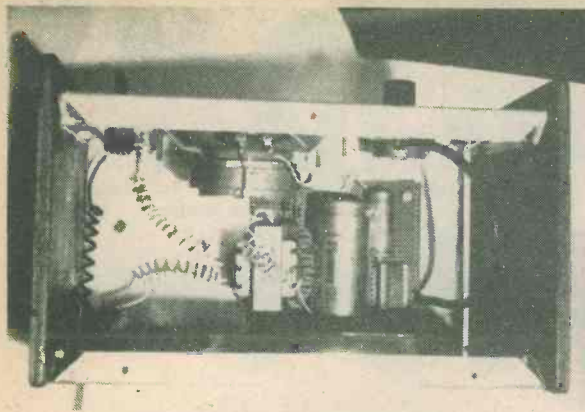

Looking down into the amplifier with the case top removed

The mains transformer is positioned so that its secondary leads are on the inside, as in Fig. 3. The author's transformer had red leads for the 12 volt ends of the secondary, and a white lead for the secondary centre-tap. This centre-tap lead connects to the lower-most copper strip in Fig. 2 at the point marked 'OV'. The two 12 volt secondary leads connect to the negative lead-outs of D1 and D2 at the points marked '12V' in the diagram.

CASE

Although inexpensive, the case is pleasing in appearance. The front panel is a 7 by 4in. 'Universal Chassis' aluminium flanged member, and this requires holes for the input socket, VR1 and the switch, together with an aperture for the speaker. The positions for these are not critical and may be adjudged from Fig. 3 and the photograph of the front panel. The socket, volume control and switch should be on a horizontal line, with the switch and the socket spaced in from the adjacent edge by the same amount.

The speaker aperture can be conveniently cut out by drilling a circle of small holes just inside the required aperture and then cleaning up the edges with a half-round file. Next drill four countersunk 4BA clear holes for the speaker and mount this with countersunk bolts and nuts. A piece of fabric, of any suitable colour, is next stretched over the whole front panel, being secured with adhesive along the top, bottom and end flanges. When the adhesive is dry, carefully cut out holes in the fabric to enable the input socket, the volume control and the switch to be fitted. It is because the fabric covers the whole of the front panel that the speaker aperture cannot be readily discerned in the photograph.

The case may now be assembled. The rear panel is another 7 by 4in. flanged chassis member with a hole cut out in it to take a grommet through which the mains lead passes. The bottom of the case is a 7 by 4in. 'Universal Chassis' flat aluminium plate with four holes drilled in it near each corner for rubber feet. The front and rear panels are next bolted to this

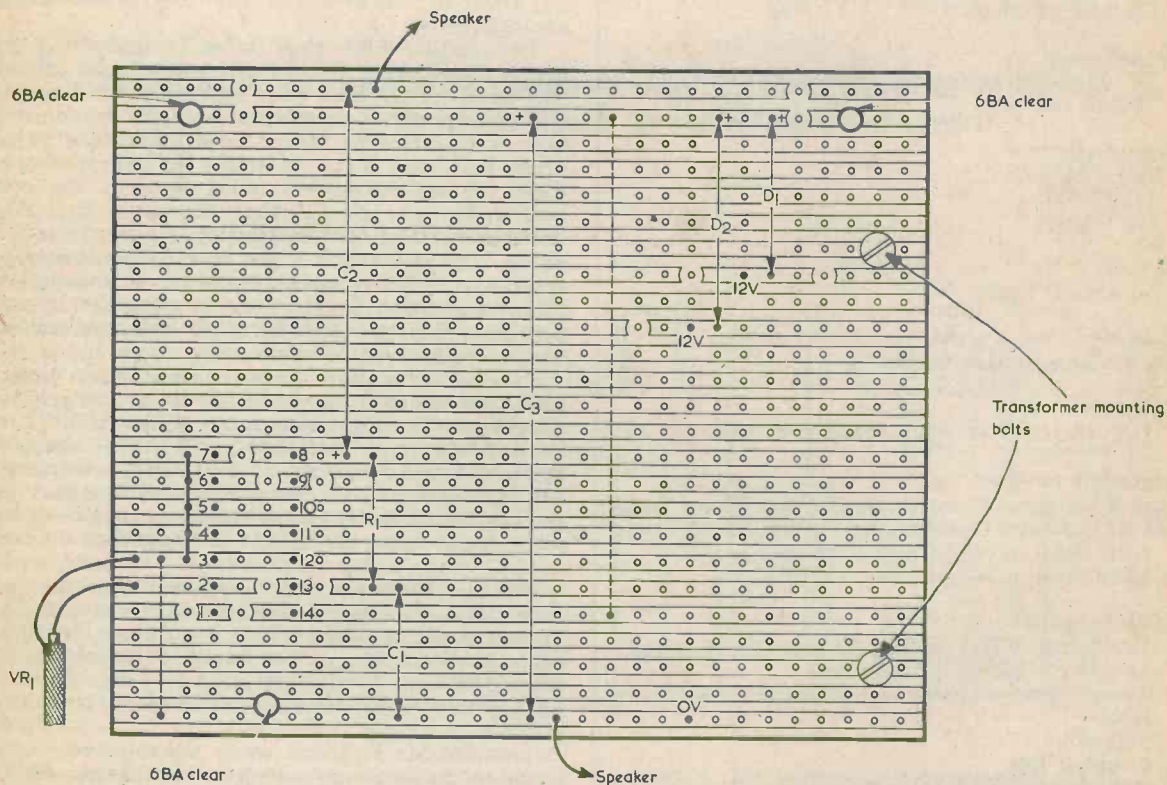

Fig. 2. Most of the components are assembled on a Veroboard panel. This diagram illustrates the copper side

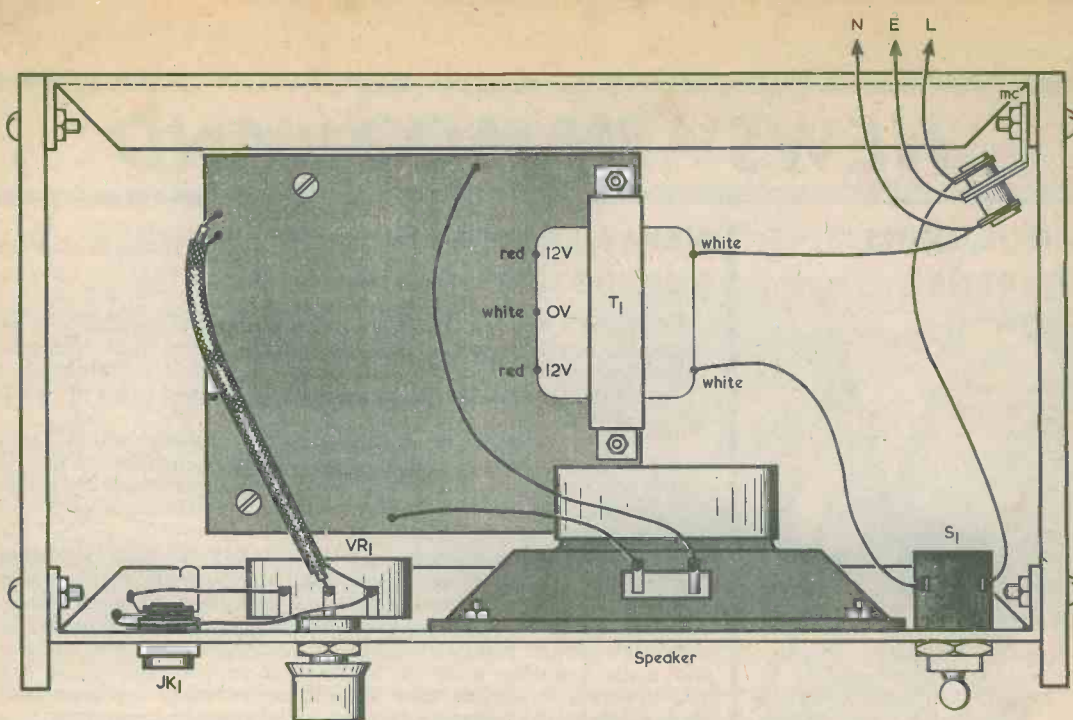

Fig. 3. The layout of the parts inside the case

plate. The two sides are pieces of 6mm. plywood measuring $4\frac{1}{2}$ by $4\frac{1}{2}$ in. and the front and rear panels are secured to these, with woodscrews, such that the plywood projects forward by about $\frac{1}{4}$ in. at the front and upward by about $\frac{1}{4}$ in. at the top. The top of the case is another piece of 6mm. plywood measuring 7 by $4\frac{1}{2}$ in. and, when it is finally fitted later, is secured with self-tapping screws passing into the top flanges of the front and rear panels. The plywood pieces may be painted, as desired, before they are fitted into place.

FINAL WIRING

Next, place the component board in position on the bottom plate and, with its aid, mark out the three 6BA clear mounting holes required here. Drill these holes, then mount the board with 6BA bolts and nuts, using extra 6BA nuts between the board underside and the metal base plate for spacing. This method of mounting will automatically connect the lower two copper strips in Fig. 2 to the base plate.

Final wiring is then carried out as in Fig. 3. The input mains lead should be suitably secured inside the case, after which its three leads connect to a 3-way tagstrip mounted near the rear. It is important to ensure that the earth wire (green-yellow) connects reliably to the earthed tag and thence to the metal parts of the case. One primary lead of T1 passes to S1, whilst the other primary lead connects to the neutral wire (blue) of the mains lead at the tagstrip. A piece of insulated wire connects the remaining tag of S1 to the live wire (brown) at the tagstrip. The two primary leads of the transformer obtained by the author were white.

Connections are also made between the board and the speaker, and between the board and VR1, as illustrated in Fig. 3. VR1 connects to the input socket as shown. If this socket has an open construction, its mounting bush will augment the chassis connection made via the component board mounting nut.

USE

It will be found that, when employed with a tuner or similar signal source, the amplifier gives good volume and reproduction. The integrated circuit is capable of offering a relatively high output. In consequence, if an unknown signal source is connected to the amplifier the volume control should be at minimum when switching on, after which it is adjusted to the desired volume level. This approach will prevent any overloading which would otherwise occur if the amplifier were connected to a signal source having an unexpectedly high amplitude level.

MAINS TRANSFORMER

The current drawn from the rectified supply increases with output level. In the prototype, with its 16 Ω speaker, the current drawn from the supply flattens out at just over 100mA at the output level where noticeable distortion commences to be introduced. Maximum amplifier volume is best maintained slightly below the point where distortion commences.

The amplifier will feed into an 8 Ω speaker, and give an output power of more than 1 watt, if a mains transformer having a secondary rated at 200mA is used. In practice, a suitable component is that listed by Home Radio; this has a 12-0-12 volt secondary rated at 250mA, which provides a comfortable current margin in excess of requirements. The transformer is larger than that used by the author and cannot be mounted on the component board. Instead, it may be bolted to the side of the case. Connections are as for the smaller transformer.

Some small $3\frac{1}{2}$ in. speakers are intended for use in portable radio receivers and may have power handling capabilities of the order of 300mW only. The speaker fitted should be able to handle the output power applied to it, this being 0.5 watt with a 16 Ω speaker and 1 watt with an 8 Ω speaker. ■

UNIQUE DRILL SHARPENER



New on the market is a unique device from James Neill of Sheffield, which allows precision sharpening of drills without the need for either grinding wheels or electric power operation.

The ECLIPSE 39 Drill Sharpener is as handy to use as a pencil sharpener and small enough to fit easily into the normal type of toolbox. It is robust, with nothing to go wrong and all metal parts are nickel plated to resist corrosion. Tests have shown that even after 50,000 complete cycles (equivalent to 6½ miles of travel over the abrasive paper) the wear on either set of wheels — the only parts of the sharpener subjected to tough use — proved to be minimal, and insufficient to affect performance over the tool's working life.

The Sharpener consists of a tough nylon base fitted with two pairs of high density polythene wheels, one pair being eccentric. Attached to the base is a 'V' shaped nylon strut, which incorporates a screw clamp to secure the drill, together with a setting gauge and adjustable stop which accurately position it. Sells for £3.67 including VAT.

B.A.E.C. EXHIBITION

The B.A.E.C. Amateur Electronics Exhibition this year will be held from July 17th to 24th inclusive, at the Shelter, centre of the Esplanade, Penarth, Glamorgan. As a result of previous exhibitions considerable sums have been given to charities.

We congratulate The British Amateur Electronics Club on recently celebrating the tenth anniversary of its foundation.

NEW HENRY'S-LINDAIR SUPERSTORE IN CROYDON

Following a successful trial run which tested the viability of offering electronic components side by side with hi-fi and audio equipment in High Street outlets, Henry's-Lindair has set up self-contained electronic components units in selected branches — the latest being in North End, Croydon.

These units, which offer counter and self-service selections, are stocked, staffed and controlled by Henry's Radio, a member of the Henry's Group of Companies, which recently created a precedent by opening the first UK self-service Electronic Supermarket offering over 5,000 types of components in Edgware Road, London.

The three Henry's-Lindair stores, already offering components in Edgware Road, Tottenham Court Road and Nottingham have now been joined by the latest acquisition — a two floor store in North End, Croydon. Apart from catering for customers who would normally have either telephoned Henry's or ordered from their catalogue, these on-the-spot units now offer a service to the do-it-yourself enthusiast. Stocking out of town branches also facilitates ordering for amateurs and professionals who urgently require replacement components.

"We're handling a high volume of business at Henry's and now find that going out to meet our customers in towns like Nottingham and Croydon is appreciated," say the directors of Henry's Radio, "and of course it's a natural progression of 'marry' electronic components to our hi-fi and audio outlets."

The components unit staff are trained to give basic technical advice and information and all units have devices such as digital displays, LED readouts, integrated circuits, transistors as well as a wide range of electronic components for the do-it-yourself enthusiast. Henry's Radio also service education authorities and industry.

The next unit to be opened will be in Harrow, Middlesex.

"QUAD" EXPORTS SUCCESS STORY

The Acoustical Manufacturing Co. Ltd., of Huntingdon, recently announced that their exports of Quad equipment represented a contribution of more than £7,000 per employee to the United Kingdom's Balance of Payments.

This is a very good achievement in the highly competitive field of High Fidelity, which is sometimes regarded as being the exclusive domain of the Japanese.

Major overseas customers, each accounting for more than ten per cent of the total are United States, Japan, Canada and Benelux, with other European markets close behind.

Quad now looks to an even better year in 1976/77 thanks to the unprecedented success of the recently introduced Quad 405 current dumping amplifier, for which export orders totalling some £400,000 have already been received.

The photo shows Peter Walker, Managing Director, with the staff of

Quad, all of whom look very happy with their achievement.



COMMENT

NEW CASSETTE DECKS AND RECEIVER IN THE AUTUMN

B. H. Morris and Company, United Kingdom distributors for Trio, announced two new stereo cassette decks and a new top-of-the-range stereo receiver earlier in the year. The products are to be introduced by October.

Trade and consumer reaction to Trio's existing stereo cassette deck, the KX-710, has been sufficiently good to prompt the introduction of the additional models. B. H. Morris are confident that the popularity of the cassette as a stereo sound source will increase even further.

The new items are: KX-620, front-loading stereo cassette deck with Dolby noise reduction system, maximum selling price £168. KX-910, stereo cassette deck with Dolby noise reduction system, maximum selling price £232, KR-9400, FM/AM stereo receiver, maximum selling price £498 (prices include VAT).

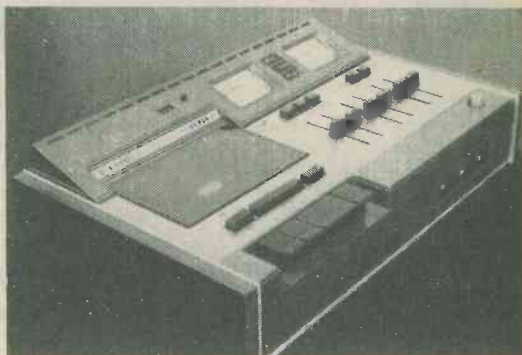

The Trio KX-910 Stereo Cassette

UNDERSTANDING TELECOMMUNICATIONS – OPEN UNIVERSITY COURSE

The past fifty years have seen a rapid development in the field of telecommunications, with television, radio and the telephone becoming an accepted part of everyday life.

An understanding of the technical advances already made, and their practical application for the present and future, form the basis of a one year course — Telecommunication Systems — being offered by the Open University.

The course, which is part of the University's Post-experience programme for 1977, examines the basic engineering principles of telecommunication systems.

Students will make a detailed study of two types of

telecommunication systems; the telephone (including data transmission), and television. The remainder of the course consists of case studies and includes an examination from the control and planning point of view, of an experimental telephone exchange.

As with all Open University courses, students need no previous educational qualifications.

Students wishing to apply for the above course or to receive further information on the Post-experience programme should write to the Post-experience Student Office, the Open University, PO Box 76, Milton Keynes, MK7 6AA. The application period lasts until October 15th.

WIRELESS PRESERVATION SOCIETY MUSEUM

A year ago we announced the proposed move of the above museum to the Isle of Wight, from South Lincolnshire.

Readers interested in the early days of radio will be glad to learn that the National Wireless Museum is now open at its new home.

It is now at Arreton Manor, home of Count and Countess Slade de Pomeroy. Here can be found a collection of crystal-sets with cats-whiskers — one made in the shape of Felix the cat! — and early receivers with bright emitter valves and plug-in coils, curved-horn loudspeakers, and so-called "portable" sets of truly gargantuan proportions (and weight!).

The prize-exhibit is undoubtedly a genuine 30-line mechanical spinning-disc televisor, made by J. Logie Baird in the late twenties, and this is still in working order.

The Museum, which is open every day of the week, is under the auspices of the Wireless Preservation Society, a non-profit making organisation exclusively devoted to the collection, restoration and preservation of radio, television and sound reproduction equipment for purely educational, cultural and historical purposes.

Curator and hon. secretary is Mr. D. Byrne, G3KPO, of Alverstone Manor, Luccombe, Shanklin, IOW.



VOLTAGE-CONSCIOUS THYRISTOR CIRCUITS

By G. A. French

The silicon controlled rectifier, or thyristor, is normally regarded as a current operated device insofar that it can be made conductive by allowing a triggering current of suitable magnitude to flow in its gate and cathode junction. There is quite a wide spread from device to device in minimum gate triggering current value, and the minimum triggering current value also varies with the voltage available across the anode and cathode at the instant of triggering. These factors usually result in the thyristor being employed simply as a switch, with gate triggering current set at a level which is comfortably in excess of the minimum required by any thyristor of the type specified.

As will be described in this month's contribution to the "Suggested Circuit" series, the thyristor can with certain limitations be alternatively employed as a voltage-conscious device, whereupon it becomes conductive when the voltage across the gate and cathode reaches a specific level. Under these conditions the thyristor has about the same level of voltage discrimination as is given at the base and emitter of a silicon power transistor, and performance is repeatable with different specimens having the same type number. This article is intended mainly for the experimenter who likes to try out new circuit concepts, and several practical working circuits which illustrate thyristor voltage operation will be discussed.

BASIC THYRISTOR

The thyristor has the basic p.n.p.n. structure shown in Fig. 1. The gate current flows from a positive source to the lower p.n. junction, which is effectively a forward biased silicon diode. When the gate current reaches the requisite triggering level, internal regenerative transistor action causes the device to become conductive, and a low voltage is then dropped between

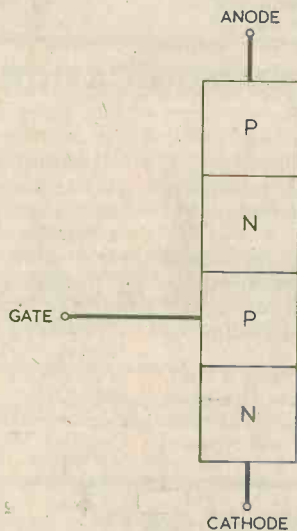

Fig. 1. The basic structure of a thyristor

the outer p and n sections. Once triggered, the device remains conductive provided that the current flowing inside it from anode to cathode is above the holding level.

Since the p.n. junction to which the gate and cathode connect is effectively a forward biased silicon diode, the forward voltage dropped across it is of the order of 0.7 volt. In Fig. 2 the thyristor is connected with its gate and cathode across a low value resistor, R_X . Current flow is from positive to negative. If a current is allowed to flow through R_X which is considerably greater than the range of gate triggering currents for the thyristor type concerned, the spread and variations in minimum triggering current value will

be almost completely swamped by the current in R_X , and the thyristor will be triggered on when the voltage across the resistor is at approximately 0.7 volt. Thus, the thyristor becomes a voltage operated device, and all specimens of a particular type number can be expected to offer an approximately similar performance with, perhaps, a spread in operating voltage across R_X ranging from about 0.65 to 0.8 volt.

Naturally, precautions have to be taken to prevent damage to the thyristor, and a further low value resistor, R_Y , is required in series with the gate to limit gate current. The circuit in which the thyristor is incorporated then has to be designed such that, under worst case conditions, the current in R_Y cannot exceed the maximum gate current rating of the thyristor.

In the circuits which will next be described, a voltage-conscious thyristor is employed to monitor a direct current, and to be triggered on the conducting condition when the current exceeds a predetermined level. The circuits apply to overload indication, or overload protection, in d.c. power supplies.

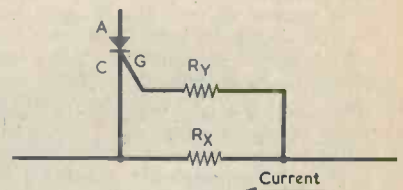
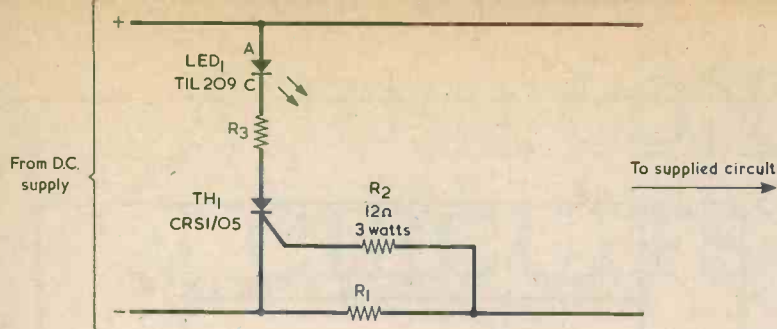

Fig. 2. Here, a current very much higher than thyristor triggering current flows through R_X . The thyristor becomes conductive when the voltage across R_X is approximately 0.7 volt



R₁ values at :

100mA	- 6.8n	4 watts
200mA	- 3.3n	8 watts
300mA	- 2.2n	12 watts
400mA	- 1.6n	20watts
500mA	- 1.3n	20watts

R₃ see text

Fig. 3. A current monitor circuit. The thyristor fires and lights the l.e.d. when the current through R₁ exceeds a predetermined level

OVERLOAD INDICATOR

Fig.3 shows a circuit which demonstrates voltage triggering. In this diagram a CRS1/05 (listed in some catalogues as CRS1/05AF) functions as a direct current overload monitor. When the current passing through R₁ causes a voltage of around 0.7 volt to be built up across it, the thyristor fires and then remains conductive. In Fig.3 the thyristor causes an l.e.d. to be illuminated, whereupon the latter gives warning that the monitor current level has been exceeded and that a fault condition in the associated equipment is therefore present. Values for R₁ suitable for currents from 100mA to 500mA are also shown in Fig.3. The wattage ratings apply to the worst case situation, which will shortly be dealt with. In practice it may be necessary to slightly adjust the resistance values if indication at the precise current concerned is required.

R₂ limits the possible gate current which can flow. The peak forward gate current rating for the CRS1/05 is 600mA and it would be desirable to work to a maximum of, say, 400mA here in practice. R₂ will therefore protect the thyristor for fault condition currents up to the level which causes some 5 volts to appear across R₁. Such a current is about 7 times the current which causes the thyristor to fire. The external circuit must, therefore, be designed such that even under short-circuit conditions the maximum current which can flow is not more than 7 times the current at which the thyristor is intended to be triggered.

The current which can safely flow through R₁ under fault conditions could be raised by increasing the value of R₂. However, the value of 12n specified for this resistor approaches the maximum which can be used if the thyristor is to function as a voltage sensitive device.

The resistor in series with the l.e.d., R₃, should have a value which causes

about 20mA to flow in the l.e.d. when the thyristor becomes conductive. It may be assumed that a total of about 2 volts is dropped in the l.e.d. and the conducting thyristor, whereupon R₃ requires a value which causes approximately 20mA to flow at the supply voltage minus 2 volts. Thus, if the supply voltage is 6 volts R₃ should be 200Ω, for 9 volts 360Ω and for 12 volts 510Ω. R₃ may be a ½ watt 10% component. R₁ and R₂ should be 5% resistors.

In Fig.4(a) the thyristor energises a relay instead of causing an l.e.d. to be illuminated when it is triggered. A break contact of the relay then disconnects the supplied circuitry so that, in the event of an overload, the supply

circuit is opened. This is a simple and quite effective arrangement for overload protection, particularly if the relay is a reasonably fast-operating component. The resistance of the relay coil is not critical provided that the current which flows through it is between some 20 and 50mA. It is found that some thyristors of the CRS1/05 type require holding currents approaching 20mA if they are to remain conductive after firing. When calculating relay coil resistance it can be assumed that about 0.7 volt is dropped in the conducting thyristor.

Since the relay switches off the overload current almost as soon as it appears, R₁ and R₂ can now have much lower wattage ratings than those shown in Fig.3.

Another overload trip circuit appears in Fig.4(b), and this is suggested for use in stabilized power supplies in which a zener diode provides a reference voltage for an output emitter follower or a voltage comparator. When the thyristor fires it causes the voltage across the zener diode to fall to a low value, thereby taking down the output voltage to a correspondingly low level. The value of R₃ should be such that at least 20mA flows in it when the thyristor fires.

The three circuits of Figs. 3, 4 (a) and 4(b) are sensitive to pulse currents and will trigger if a high value capacitor is applied across the supply rails after R₁. The circuits may also trigger on switch-on if they are inserted into a power supply circuit before a high value smoothing capacitor. In consequence, the circuits of Figs. 3 and 4 (a) should be inserted, if possible, after any smoothing capacitors that may be present. With

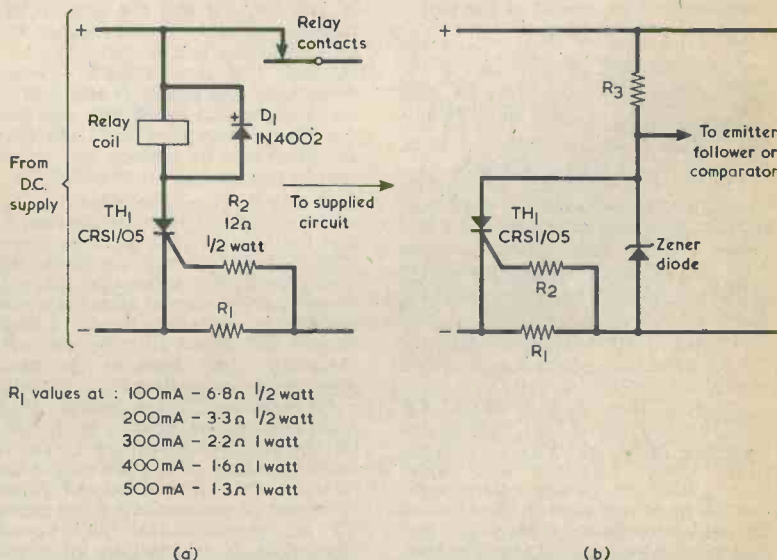

R₁ values at :

100mA	- 6.8n	1/2 watt
200mA	- 3.3n	1/2 watt
300mA	- 2.2n	1 watt
400mA	- 1.6n	1 watt
500mA	- 1.3n	1 watt

Fig. 4(a). A simple overload protection circuit. The relay energises and disconnects the supplied circuit when the thyristor fires (b). Another protection circuit which could be used in zener diode stabilized supplies. The values of R₁ and R₂ are the same as in (a)

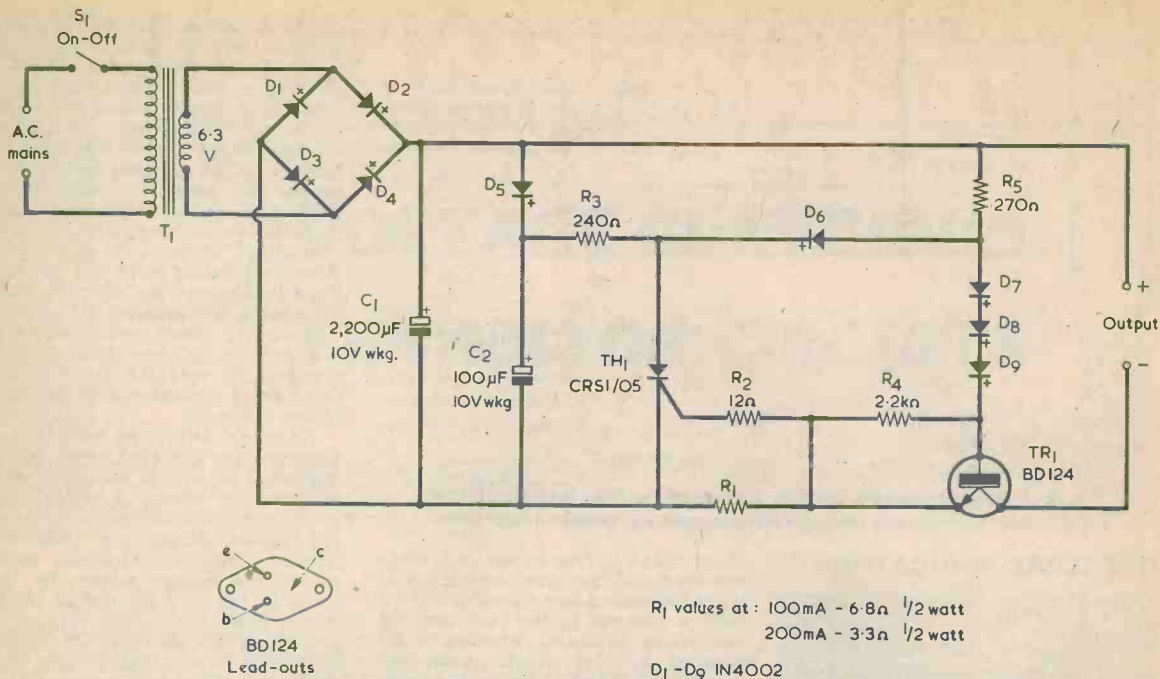

Fig. 5. In this circuit the output switches off automatically at the overload trip current value

Fig.4(b), any subsequent smoothing capacitors should have a fairly low value, say 50 μ F for a 100mA trip, 100 μ F for a 200mA trip, and so on. The actual value will need to be determined by experiment. The susceptibility to triggering at switch-on with smoothing capacitor charging surges represents a limitation to the usefulness of the circuit of Fig.4(b).

COMPLETE SUPPLY

A simple low voltage protected supply for currents up to 200mA has been checked out by the author and is illustrated in Fig. 5. This offers an output voltage of approximately 8 volts, dropping to 7.4 volts at 200mA.

The 6.3 volt secondary of a heater transformer is connected to the bridge rectifier given by D1 to D4, and a rectified voltage then appears across reservoir capacitor C1. A positive voltage is available across C2, which becomes charged via D5, and this is applied to the anode of the thyristor by way of R3. Until it fires, the voltage on the thyristor anode is the same as that at the junction of D5 and C2.

A current flows through R5, D7, D8 and D9 to the base of TR1, turning this transistor hard on. TR1 is a small silicon power transistor and, under these conditions, causes a very small voltage drop to be given between its emitter and collector. The output terminals of the supply may then be connected to a suitable load. Since the junction of R5 and D7 is negative of the anode of the thyristor, no current flows in diode D6.

When the current drawn by the load exceeds the trip value the thyristor

fires and its anode potential falls to about 0.7 volt above the left-hand negative rail. Diode D6 now becomes conductive, drawing the lower end of R5 down to about 1.4 volts above the left-hand negative rail, whereupon the voltage between the lower end of R5 and the emitter of TR1 is well below that needed for forward current to flow in D7, D8, D9 and the base-emitter junction of TR1. This transistor cuts off completely, and no current flows in the load. The circuit stays in this condition until the supply is switched off and switched on again with the fault condition removed. Should the fault condition still be present, the circuit simply trips out again at switch-on.

It may be considered that only two silicon diodes are required between R5 and the base of TR1. The circuit was initially tried out with two diodes, but it was found in practice that TR1 still passed a small current after the circuit had tripped. Inserting the third diode caused TR1 to cut off completely. R4 maintains TR1 base at the same potential as its emitter after tripping.

R3 is returned to the junction of D5 and C2 instead of direct to the positive rail in order to allow the circuit to function reliably when the output terminals are short-circuited. An output short-circuit causes the voltage across C1 to be momentarily reduced, whereupon it is possible for insufficient anode voltage to be available, if R3 were connected direct to the positive rail, to enable the thyristor to fire. With the circuit as shown, C2 retains its charge when the voltage across C1 drops, and the initial

thyristor anode current is drawn from C2 for a very short period until the full rectified voltage appears once more across C1. A different set of circumstances occurs if the output terminals are short-circuited when the circuit is switched on. In this case, the thyristor triggers on before TR1 has reached the fully turned on state, whereupon adequate anode voltage is available for the thyristor. The short-circuit protection given by the circuit is very effective and virtually instantaneous.

Again, the problem of switch-on current surges arises if a high value capacitor is connected across the output terminals. Assuming a light d.c. load, the author's prototype circuit would tolerate capacitances up to 50 μ F across the output terminals in the 100mA version, and up to 100 μ F in the 200mA version.

Transistor TR1 suffers very low dissipation as it is normally either turned hard on or is fully cut off, and it does not need to be mounted on a heat sink. A power transistor is specified since transient current surges when the output is short-circuited will be high.

The current rating of the mains transformer secondary is 1 amp or more. Experimenters who require a higher output voltage may employ mains transformers having secondary voltages up to some 10 volts, increasing the values of R3 and R5 proportionately. The working voltages of C1 and C2 may, then, also need to be increased. Resistors R1 and R2 are 5%, as before, with R2 at 1/2 watt. R3, R4 and R5 may be 1/2 watt 10% types.

AUDIO CONTROL CIRCUITS — 1

By P. R. Arthur

This article, the first of a 3-part series, introduces the Motorola MC3340P electronic attenuator and then describes its use in an audio compression amplifier and an audio squelch unit. The articles to come will describe other applications for the MC3340P.

One of the most interesting and useful of the many integrated circuits currently available is the Motorola MC3340P electronic attenuator. It may be employed in a number of audio control circuits, and this series of articles will demonstrate how it can be used in a compression amplifier, an audio squelch circuit, a stereo dynamic noise limiter and an automatic fader.

The MC3340P is in an 8-pin d.i.l. package with pins 4 and 5 'NC'. It has superseded the Motorola MFC6040, which was in a 6-pin 643A package with staggered pins. Both i.c.'s have the same circuit and electrical specifications, and their pin functions are illustrated in Fig. 1. All the circuit and layout diagrams in this series in which the i.c. appears are applicable to the MC3340P.

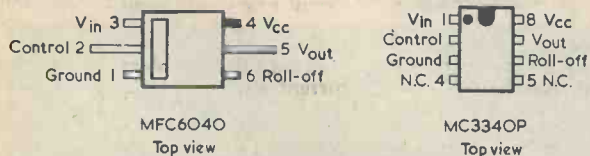

Fig. 1. The MC3340P electronic attenuator is electrically identical with the earlier MFC6040. The pinning of both types is illustrated here

MC3340P BASICS

The internal circuitry of the MC3340P incorporates 10 transistors, 3 diodes and 18 resistors, and it consists basically of an amplifier having a typical voltage gain of 13dB. This gain can be reduced by applying a positive voltage to the control terminal of the device, and the control voltage can reduce the gain by any level up to a typical figure of 90dB.

It is also possible to control the gain of the device by connecting a resistor between the control terminal and the negative supply. If a variable resistor is employed here in conjunction with the MC3340P it can function as a remote volume control.

Fig. 2 shows the circuit of a simple remote volume

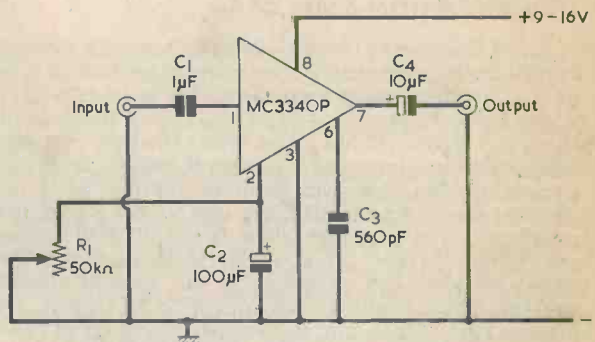

Fig. 2. Illustrating the basic operation of the MC3340P. The variable resistor functions as a remote volume control, and its wiring is bypassed by C2

control using the MC3340P. The point of this circuit is that the variable control resistor, R1, can be mounted a long distance away from the main circuit. There is no risk of stray pick-up in the connecting wires since they are only carrying d.c. and are decoupled by C2.

In Fig. 2 the input is coupled to pin 1, of the i.c. via a d.c. blocking capacitor, C1. The output is taken from pin 7. The control resistor (or a control voltage) is connected to pin 2 of the device. Since the MC3340P has a rather wide bandwidth, with a -6dB point in excess of 10MHz, it is advisable to provide high frequency roll-off to ensure good stability in audio applications. This is given by C3, which connects between pin 6 and the negative supply.

Typical performance graphs are given in Figs. 3(a) and (b). The graph in Fig. 3(a) shows attenuation against positive control voltage at pin 2 whilst that of Fig. 3(b) shows attenuation against control resistance in the circuit of Fig. 2. In both graphs the zero dB reference level corresponds to the (typical) 13dB gain of the device. Therefore, the -30dB level, for example, corresponds to an actual attenuation of 17dB.

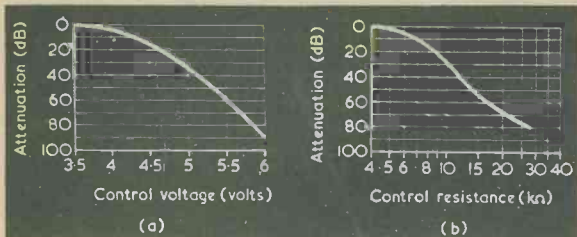

Fig. 3(a). Curve showing attenuation against control voltage. The zero dB reference corresponds with the typical voltage gain of 13dB
 (b). The attenuation curve given when control is exerted, as in Fig. 2, by a variable resistor

The device has a low level of distortion, this being typically only 0.6% total harmonic distortion at 1kHz and 13dB gain with the maximum permissible input of 500mV r.m.s. When the gain of the i.c. is taken below unity this figure does increase, but is still only about 3% at the -40dB point.

The absolute maximum supply voltage rating of the MC3340P is 20 volts.

COMPRESSION AMPLIFIER

Apart from using the MC3340P in a remote volume control circuit, perhaps the most obvious application is in an audio compression amplifier. This is an amplifier where the voltage gain is dependent upon the level of the input signal. At low input levels the gain remains fairly constant, but after a certain threshold level has been exceeded the gain reduces rapidly with increasing input. In consequence, the output signal has a reduced dynamic range when compared with the input signal. If the input signal is kept above the threshold level the output level will remain almost constant. The amplifier provides what is, in fact, an audio a.g.c. system, and it is sometimes referred to as a constant volume amplifier. This type of circuit is widely used in modern tape recorders, and is the basis of automatic recording level controls. It could also be employed in the audio stages of a t.r.f. or direct conversion radio receiver, as these rarely incorporate any form of r.f. automatic gain control. There are probably many other useful applications for the compression amplifier.

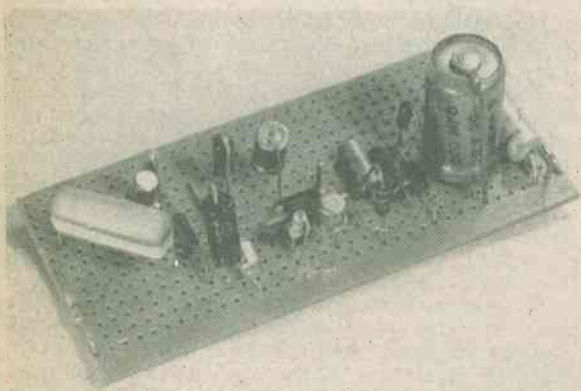

The compression amplifier makes a neat assembly on its Veroboard panel

AMPLIFIER CIRCUIT

Fig. 4 gives a circuit for a practical audio compression amplifier incorporating the MC3340P. Here, the input voltage is applied to the I.C. via C3. R6 sets the quiescent gain of the I.C. at a little in excess of unity.

The output of the i.c. is coupled via C2 to the base of TR1, which is a high gain transistor connected as a common emitter amplifier. It has rather a low voltage gain in the present circuit, however, since the unbypassed emitter resistor, R2, provides a high level of negative feedback. The feedback ensures low noise and distortion levels. The signal at the collector of TR1 is coupled to the output terminal by way of C1.

The i.c. output is also coupled, via C5, to the base of TR2. This is a very high gain common emitter amplifier which has R5 as its collector load and is provided with base bias by R4. The output of TR2 couples to a voltage doubling circuit incorporating D1 and D2. C8 smoothes the rectified audio signal and produces a steady d.c. bias which is fed to the control pin of the MC3340P.

At low input signal levels the voltage across C8 is too small to significantly affect the gain of the i.c., but at higher signal levels it is large enough to greatly reduce the gain.

COMPONENTS

Compression Amplifier

Resistors

(All miniature ¼ watt, 5 or 10%)

- R1 4.7kΩ
- R2 390Ω
- R3 1.5M
- R4 470kΩ
- R5 2.2kΩ
- R6 6.8kΩ

Capacitors

- C1 10μF electrolytic, 16V Wkg.
- C2 0.47μF type C280 (Mullard)
- C3 2.2μF electrolytic, 25V Wkg.
- C4 560pF polystyrene
- C5 10μF electrolytic, 16V Wkg.
- C6 25μF electrolytic, 16V Wkg.
- C7 10μF electrolytic, 16V Wkg.
- C8 200μF electrolytic, 6V Wkg.

Semiconductors

- IC1 MC3340P
- TR1 BC108C
- TR2 BC108C
- D1 OA91
- D2 OA91

Switch

- S1 s.p.s.t. toggle

Miscellaneous

- Veroboard, 0.1in. matrix, 36 holes x 14 strips
- Veropins (as required)
- Wire, etc.

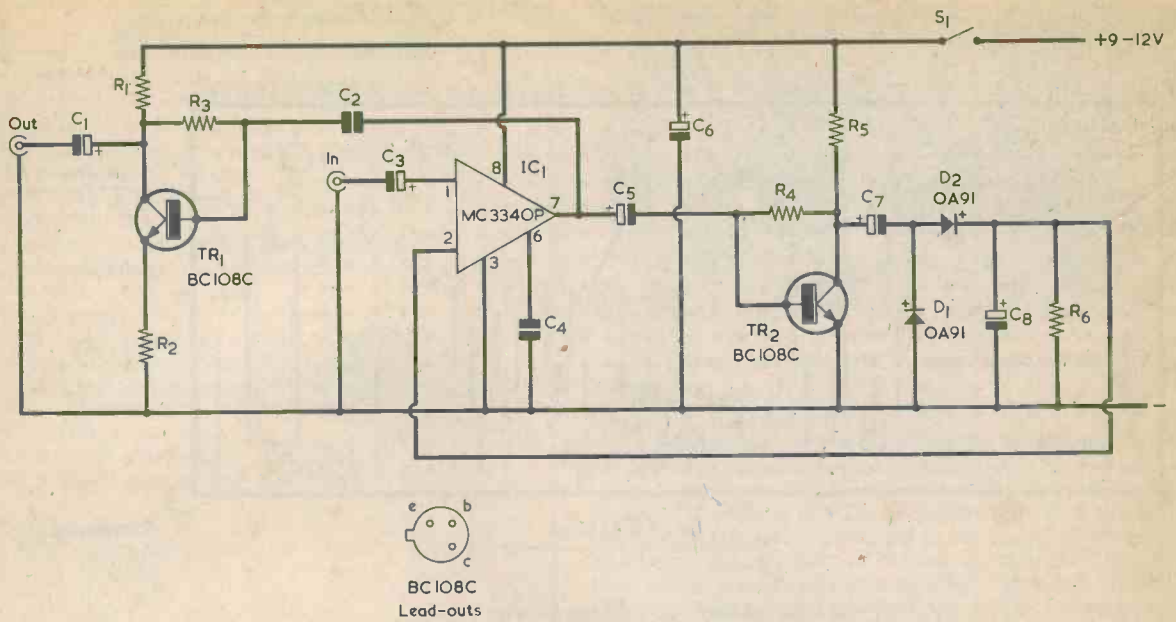

Fig. 4. The circuit of the audio compression amplifier

The compression effect of the amplifier can be clearly seen from the graphs of Fig. 5, which show the amplifier input voltage against the output voltage. If necessary, the output level can be increased by reducing the value of R2. This will also cause a slight increase in overall noise and distortion levels.

For best results, it is important that the transistors are high gain types, this being particularly the case with TR2. BC108C transistors were used in the prototype, but BC109C types would be equally suitable. These have the same lead-out layout as the BC108C. BC109C's may also be used in place of

BC108C's in the other circuits which are described later.

The compression amplifier has an almost instantaneous attack, but it takes a few seconds for the a.g.c. voltage to die away when there is little or no input signal immediately after a high input. This is known as hysteresis, and is usually incorporated in compression amplifiers. It prevents the gain of the amplifier returning to maximum during brief intervals between words or between loud musical phrases. The increased noise level which could otherwise accompany the gaps in the signal would be extremely undesirable. The

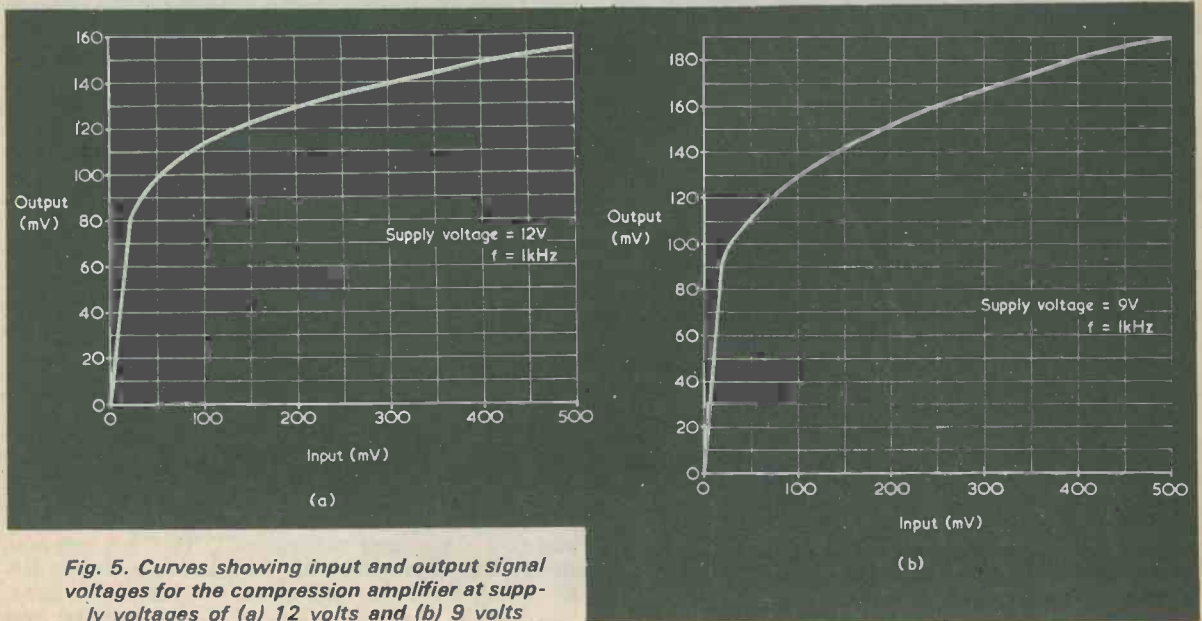

Fig. 5. Curves showing input and output signal voltages for the compression amplifier at supply voltages of (a) 12 volts and (b) 9 volts

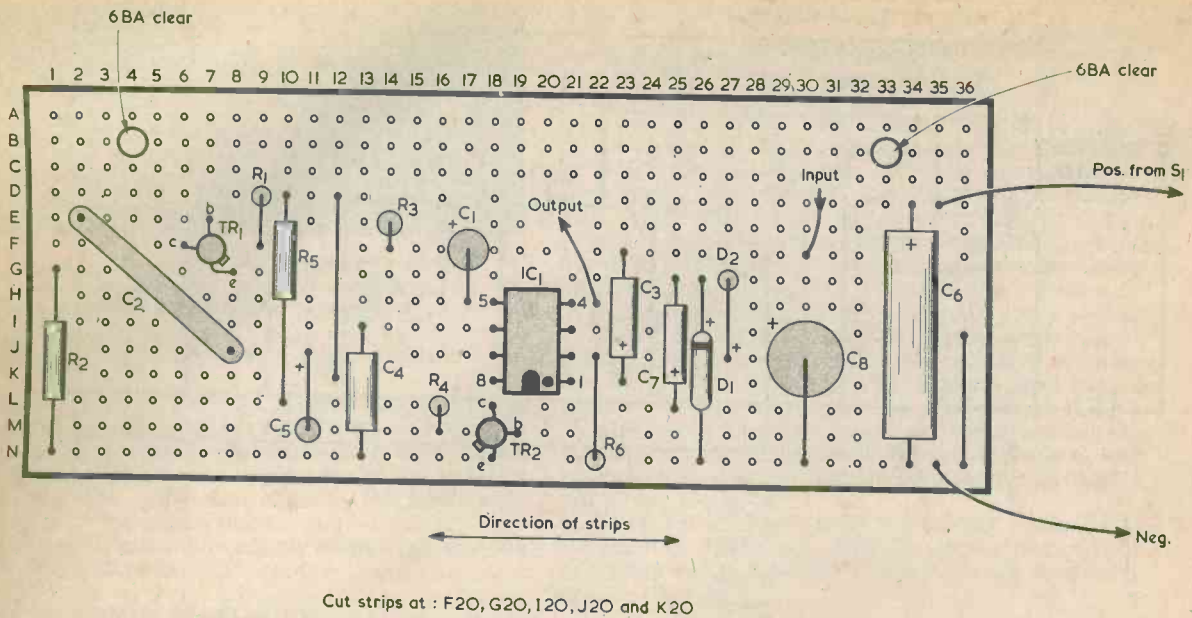

Fig. 6. The component side of the Veroboard panel on which the compression amplifier is assembled

decay time of the circuit can be altered if wished. The higher the value of C8, the longer the decay time.

The current consumption of the unit is approximately 10mA from a 9 volt supply and 14mA from a 12 volt supply.

CONSTRUCTION

The compression amplifier is assembled on a 0.1in. matrix Veroboard panel having 36 holes by 14 copper strips. The component layout is shown in Fig. 6.

First drill the two mounting holes, then cut the strips at the points specified in the diagram. Next, solder in the various components. Use 0.1in. Veropins where connections are made to the input, output and power supply.

AUDIO SQUELCH

Squelch circuits are employed to reduce or inhibit the a.f. output of a system in the absence of signals of

usable or pre-determined amplitude. They tend to be associated with radio receivers rather than audio circuits, although they can be usefully employed with the latter. In receivers fitted with a squelch system the demodulator may be muted unless a carrier wave is received. A squelch circuit is also, for instance, included in the more sophisticated f.m. tuners and receivers so that, when tuning between stations, the high level of noise which the detector would otherwise produce is suppressed.

Squelch can be employed in any audio circuit where there is normally a fairly high background signal, which the squelch can suppress in the absence of the main signal. An example of the use of audio squelch is in the a.f. stages of a communications receiver working with a.m. or s.s.b. signals. Here, the squelch can cut out the interference between spoken phrases. It can be used in the same way on any audio equipment where speech is handled with a high level of background noise.

SQUELCH CIRCUIT

In the audio squelch circuit shown in Fig. 7, a transistor which is used as a switch is connected between the control terminal of the MC3340P and the negative supply. This transistor is TR2.

Under quiescent conditions or with low input signal levels, TR2 receives little or no base bias and pin 2 of the MC3340P is in effect open-circuit. The i.c. thus provides some 80dB of attenuation to the input signal, which it receives via C3. The output from pin 7 of the i.c. is thus negligibly low.

The input signal is also fed to the base of TR1 by way of d.c. blocking capacitor C1. TR1 is a common emitter amplifier which has its gain controlled by R4. R4 is part of the unbypassed emitter resistance, and it controls the level of negative feedback applied over

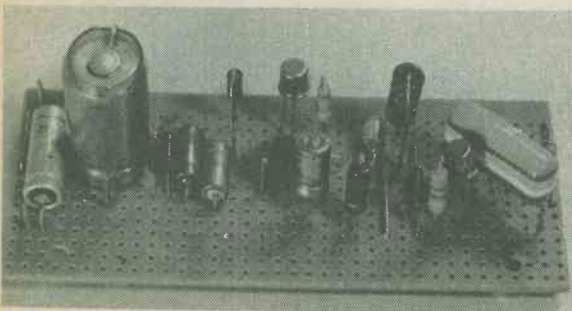

Another view of the compression amplifier

COMPONENTS

Squelch Unit

Resistors

(All fixed values miniature $\frac{1}{4}$ watt, 5 or 10%)

R1 1.5M Ω

R2 4.7k Ω

R3 47 Ω

R4 5k Ω or 4.7k Ω , 0.1 watt skeleton potentiometer, horizontal mounting (see text)

Capacitors

C1 10 μ F electrolytic, 16V Wkg.

C2 10 μ F electrolytic, 16V Wkg.

C3 10 μ F electrolytic, 16V Wkg.

C4 10 μ F electrolytic, 16V Wkg.

C5 560pF polystyrene

C6 10 μ F electrolytic, 16V Wkg.

C7 25 μ F electrolytic, 16V Wkg.

Semiconductors

IC1 MC3340P

TR1 BC108C

TR2 BC108C

D1 OA91

D2 OA91

Switch

S1 s.p.s.t. toggle

Miscellaneous

Veroboard, 0.1in. matrix, 24 holes x 16 strips

Veropins (as required)

Wire, etc.

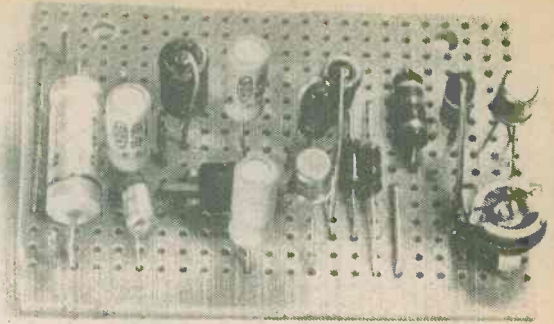

The audio squelch unit in its completed form

the stage and hence the gain. The output from the collector of TR1 is fed to a voltage doubling rectifier circuit consisting of C2, D1, D2 and C4. The positive voltage produced on the positive terminal of C4 is

applied to the base of TR2.

R4 is adjusted such that, when the input signal exceeds the required threshold level, a base bias voltage is produced across C4 which is sufficiently high to cause TR2 to turn on. This results in pin 2 of the i.c. being virtually short-circuited to the negative supply, and the full 13dB gain of the i.c. is realised. The i.c. thus either suppresses or amplifies the input signal, this depending upon whether the latter is below or above the threshold level. R4 can be adjusted to give a threshold level within the range of about 100mV to 500mV.

As the circuit contains no form of regenerative triggering it is possible for TR2 to be in an intermediate state between fully on and fully off, and for the MC3340P to have a corresponding gain between full attenuation and maximum gain. However, the range of input levels that produce this intermediate state is very limited, and in practice the intermediate state does not appear except momentarily as the circuit changes over. The existence of the intermediate state is no disadvantage, since it ensures a smooth transition and prevents an abrupt click being produced during the changeover, as could occur if triggering were employed.

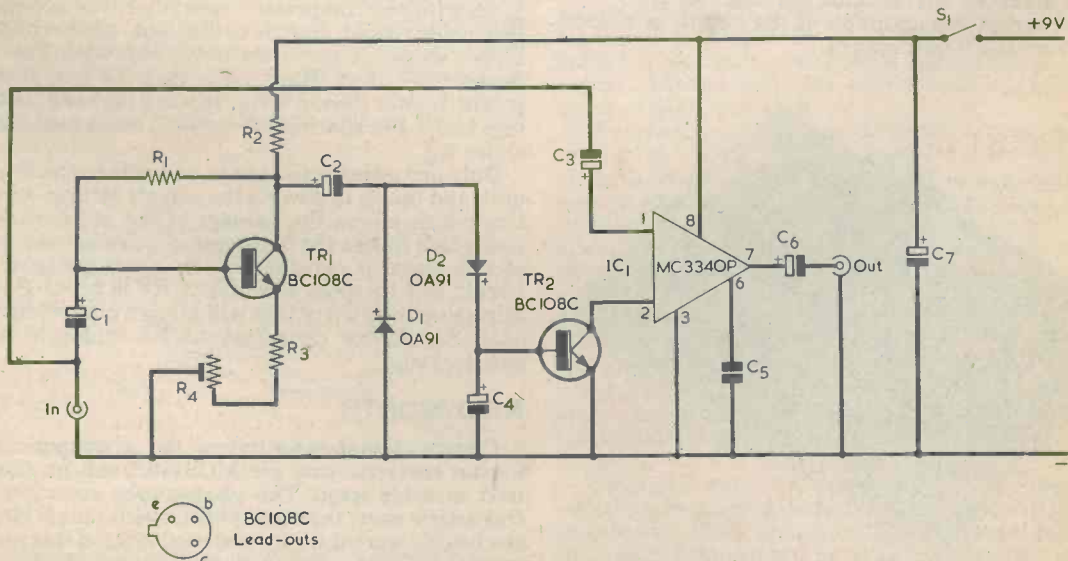
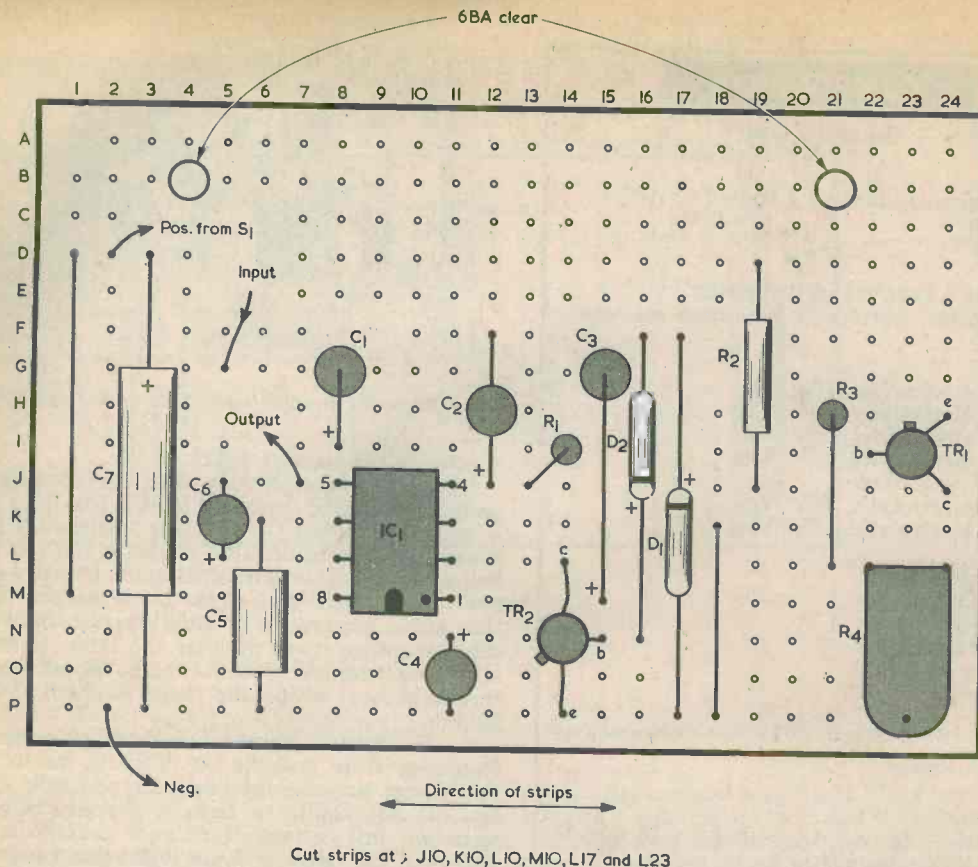

Fig. 7. The audio squelch unit. This suppresses all input signals below a pre-set threshold level



Cut strips at J10, K10, L10, M10, L17 and L23

Fig. 8. The squelch unit components are wired up on a Veroboard panel in the manner shown here

The circuit has a degree of hysteresis, but the decay time is much shorter than with the audio compression amplifier. In some applications it might be advantageous to shorten the decay time still further. This can be achieved by reducing the value of C4.

The current consumption of the circuit is around 8mA from the 9 volt supply.

CONSTRUCTION

The squelch unit is assembled on a Veroboard panel of 0.1in. matrix having 24 holes by 16 copper strips. The component side of this board is illustrated in Fig. 8. As with the compression amplifier, the two mounting holes should first be drilled out, after which the copper strips are cut at the points indicated. The components are then fitted. Note that R4 is a skeleton potentiometer having 0.2in. spacing between its track tags and 0.4in. spacing between the track tags and the slider tag.

Only one adjustment has to be made to the finished unit, and that is to give R4 the correct setting. Any setting which allows the passage of the required signal and which blocks the background noise in the absence of this signal is satisfactory. In many instances, the circuit will be most effective if R4 is set to give the minimum sensitivity that will allow a normal signal to pass. Sensitivity decreases as R4 slider is turned anticlockwise.

NEXT MONTH

Constructional information for a dynamic noise limiter incorporating the MC3340P will be given in next month's issue. The photographs accompanying this article show the earlier MFC6040. This is because the boards were initially designed around this i.c. and were then later adapted to take the MC3340P.

(To be continued)

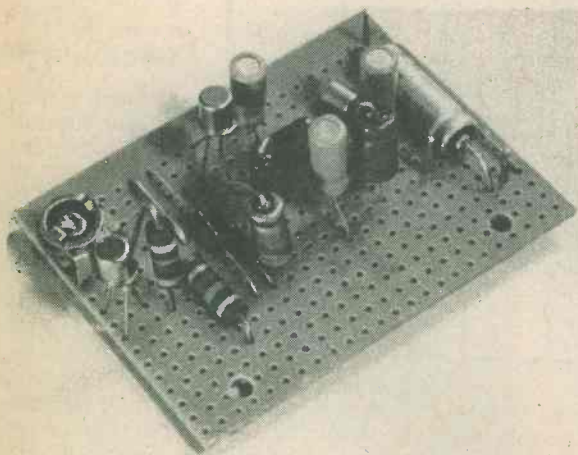

The squelch unit as seen from the other side

MEASURING MAINS CURRENT

by J. D. Sneddon

How to increase the usefulness of low cost multi-testmeters.

Many of the more inexpensive multi-testmeters have direct voltage ranges, direct current ranges and alternating voltage ranges, but no alternating current ranges at all. The lack of alternating current ranges represents a disadvantage on those occasions when it is desired to determine the current drawn from the mains supply by an item of mains-powered equipment. Fortunately, it is possible to employ a simple technique to enable at least an approximate idea of mains current to be obtained with the aid of any multi-testmeter having alternating voltage ranges.

SERIES RESISTOR

If the current to be measured is less than 1 amp, a 10Ω resistor rated at 10 watts is inserted in series with the mains supply, as in the accompanying diagram, and the voltage dropped across it measured with a multi-testmeter switched to a low alternating voltage range. Converting alternating voltage readings to current readings is very simple. From Ohm's Law a current of 1 amp in 10Ω causes a voltage drop of 10

volts. Similarly, a current of 0.1 amp causes a voltage drop of 1 volt. The alternating current flow, in amps, is equal to the alternating voltage reading divided by 10. Thus, a voltage reading of 6 volts indicates a current flow of 0.6 amp.

For currents from 1 to 10 amps, the series resistor may be 1Ω at 10 watts, whereupon the current in amps is equal to the voltage dropped across it. A reading of 4 volts therefore indicates a current of 4 amps. It may be difficult to obtain a 1Ω 10 watt resistor, but it should be possible to make this value up with a suitable combination of two or more resistors. For instance, Henry's Radio list 0.5Ω 5 watt resistors, and two of these in series would provide the required resistance and wattage rating. Also listed by Henry's Radio are 2Ω 10 watt resistors; two of these in parallel would give 1Ω with double the required wattage.

Ideally, the series resistor should be a close tolerance component, whereupon measurements having quite a high degree of accuracy may be obtained. But, in practice, readings with an accuracy within plus and minus 10% should be acceptable for most requirements. The series resistor will inevitably be a wire-wound component, or a combination of wire-wound components, and general experience with wire-wound resistors indicates resistance accuracies well within a 10% tolerance.

The maximum voltage dropped across the 10Ω resistor at 1 amp, and across the 1Ω resistor at 10 amps, is 10 volts. The small voltage drop given by the resistor should not affect most conventional mains-supplied equipment. It may, however, cause a slight modification in performance of the older all-valve, or valve and transistor, monochrome television receivers. These have a half-wave h.t. rectifier operating directly from the mains supply and tend to be sensitive to changes in supply source resistance. In any event, the current drawn by receivers of this type is markedly non-sinusoidal, and current indications given by measuring instruments calibrated for sinusoidal alternating current or voltage would be inaccurate.

Finally, it must be remembered that the series resistor is connected to the mains supply, and that it is possible to obtain dangerous shocks from it and from the meter connections to it. In consequence, all the usual common-sense precautions against accidental shock must be strictly observed. ■

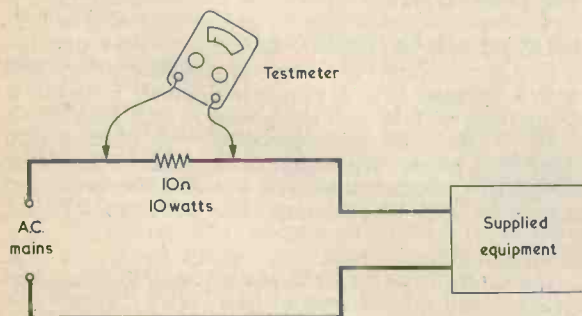

Mains current may be measured by inserting a low value resistor in series and measuring the alternating voltage dropped across it

SHORT WAVE NEWS

FOR DX LISTENERS



By Frank A. Baldwin

Times = GMT

Frequencies = kHz

For those readers who operate mostly on the higher frequency bands, the few Dx stations listed here may be of some interest.

● NORTH KOREA

Pyongyang has been logged on several channels of late, on 6338 at 1600 with YL in Korean in the External Service to the Middle East and Africa; on 9420 at 1621 with OM in Russian to Europe; on a measured 11534 at 1147, OM in Japanese in the service to Japan, also in parallel on 6770.

Pyongyang may also be logged on 6576 where we heard a song in Korean and some local music in the English programme to Europe at 2120.

● SOMALIA

Radio Mogadishu on a measured 9586 at 2025, a programme of local folk music and songs in vernacular, despite the published schedule!

● MOZAMBIQUE

Maputo on 9620 at 2004, OM and YL in Portuguese then into programme of African chants and music.

● DAKAR

Radio Senegal on 11895 at 1925, OM with talk in French followed by local music and drums in typical African style.

● SRI LANKA

Colombo on 11800 at 1925, Euro-style jazz records with announcements in English, newscast at 1930 after station identification.

CURRENT SCHEDULES

The schedules published here are correct at the time of writing but some may be subject to change at very short notice — or in some cases no notice at all!

● EGYPT

The Overseas Service of "Radio Cairo" presents a programme in English for Europe from 2200 to 2315 on 9805 with a newscast at 2215.

Some other transmissions in English are those to South Asia from 1315 to 1445 on 17920 and to Africa in the "Voice of Africa" programmes from 1715 to 1845 on 17890 and from 2030 to 2200 on 17725.

● INDONESIA

"The Voice of Indonesia", Jakarta, currently operates External Service in English as follows — from 0900 to 0930 on 9710 and 11790 to Malaysia, Singapore, S.E.Asia and the Pacific; from 1100 to 1200 on 11790 to Australia, New Zealand and the

Pacific; from 1400 to 1500 on 9710 and 11790 to Australia, New Zealand and the Pacific and from 2330 to 2400 to Malaysia, Singapore, S.E.Asia and the Pacific.

● PORTUGAL

Radiodifusao Portuguesa, Lisbon, now radiates the English programme for India and the Middle East from 1400 to 1430 on 21495.

● ISRAEL

Transmissions in English from Tel Aviv are now as follows — from 0500 to 0515 on 9435 and 12045 to Western Europe; from 1200 to 1230 on 15488 and 17685; from 2000 to 2030 on 9815 and 11645 to Western Europe and from 2230 to 2300 on 11625 to West Coast of North America.

● SYRIA

"Radio Damascus" radiates a programme in English directed to Europe from 2030 to 2200 on 9545.

AROUND THE DIAL

● BRAZIL

R. Caiari, Porto Velho, on 4785 at 0040, sports commentary in Portuguese. Schedule is from 0830 to 0230 and the power is 10kW.

R. Triangulo Mineiro, Uberaba, on 4965 at 2040, sports commentary in Portuguese. Schedule is from 0800 to 0300 and the power is 5kW.

R. Brasil Central, Goiania, on 4985 at 2105, OM with sports commentary in Portuguese. Schedule is from 0800 to 0500 but sometimes around the clock. The power is 5kW.

● DOMINICAN REPUBLIC

R. Clarin, Santo Domingo, on 4850 at 0258, OM with a newscast of local events in Spanish. Schedule is from 1000 to 0415 and the power is 3kW.

R. Norte, Santiago, on 4807 at 2320, Latin American music with songs in Spanish. Schedule is supposedly around the clock but has been reported closing at 0400 on occasions. The power is 1kW.

● RHODESIA

Gwelo on 3396 at 1800, station identification and programme about some new laws "from the Bulawayo studios". This is the General Service which operates on weekdays from 0355 to 0545 and daily from 1545 to 2200 (Sundays to 2100) the power being 100kW; from 0545 (Sundays from 0500) to 0615 daily with a power of 20kW.

● **YEMEN**

Aden on **5060** at 0306, OM with Moslem chants. Schedule is from 0300 to 0530 (Fridays to 2200 continuous) and from 1100 to 2200. The power is 7.5kW.

● **CAPE VERDE IS.**

Radio Clube Cabo Verde, Praia, on **3886** at 1940, guitar solos, OM with announcements in Portuguese. Listed on **3883**, the schedule is from 0845 to 0945 and from 2000 to 2400. The power is 5kW.

● **VENEZUELA**

Voz de El Tigre, El Tigre, at 0250 on **3255**, guitar music with songs in Spanish. The schedule of this one is from 1000 to 0300 but the closing time is likely to vary up to as late as 0500 and just to make life more exciting the identification is sometimes given as "R. Continente". The power is 1kW.

R. Monogas, Maturin, on a measured **3327** at 0307, Latin American music, YL with song in Spanish. Schedule is from 1000 to 0400 but has been reported closing as late as 0545. Listed on **3325**, the power is 5kW, sometimes announced as "Voz de Maturin".

R. Mundial, Caracas, on **5050** at 0410, songs and music in local pops programme. Schedule is on a 24-hour basis and the power is 1kW.

R. Impacto, Valencia, on **3355** at 0245, local music in typical style after identification. This station seems to have changed the identification from the former "Radio Valencia" or perhaps, like many other Venezuelans, now uses two differing identifications.

R. Tachira, San Cristobal, on **4830** at 0253, local pops, OM with announcements in Spanish. Schedule is from 1000 to 0500 and the power is 10kW.

● **ECUADOR**

Voz del Rio Carrizal on **3260** at 0104, programme of local pops on records with announcements in Spanish, poor modulation. This one has a schedule from 1100 to 0300 but has been heard as late as 0400 according to some reports. The power is 2kW.

R. Nac. Espejo on a measured **4679** at 0135, OM with jingles in Spanish, guitar and songs. Schedule is 24-hour continuous and the power is 5kW.

R. Iris, Esmeraldas, on **3380** at 0254, local pops on records, OM with announcements, jingles. Schedule is from 1100 to 0500 but can, and does, overrun to 0530 on occasions. Power is 2kW.

Emisora Gran Colombia on **4910** at 0325, programme of local pops, guitar music, OM with songs in Spanish. Schedule is from 1100 to 1500 and from 2200 to 0500 but has been logged when closing at 0540 and can vary in frequency from that shown up to **4912**. The power is 5kW.

● **COLOMBIA**

Emisora Nuevo Mundo, Bogota, on **4755** at 0525, soft lullabies in Spanish with guitar music to match. Schedule of this one is around the clock. Sometimes identifying as "R. Caracol", the power is 1kW.

R. Nueva Granada, Bogota, on **6180** at 0153, OM with an excited sports commentary in Spanish. The schedule is 24-hour and the power is 10kW.

● **BOLIVIA**

R. Abaroa, Riberalta, on a measured **4738** at 0303, local pops, announcements and commercials in Spanish. Schedule is from 2300 to 0430 but the closing time can vary from 0400 to 0445. Sometimes iden-

tifying as "Voz de Riberalta", the power is 0.5kW.

● **GUATEMALA**

R. Cultural, Guatemala City, on **3300** at 0331, Latin American music, OM with songs in Spanish. Schedule is from 1100 to 0830 and the power is 5kW.

Voz de Nahuala, Nahuala, on **3360** at 0236, programme of local pop records with announcements and jingles in Spanish. Schedule is from 1100 to 1300 and from 2230 to 0430 and the power is 1kW.

● **ECUADOR**

R. Splendit, Cuenca, on **5025** at 0405, dance music on records, commercials, OM in Spanish. Schedule is from 1100 to 0430 but can vary sign-off up to 0530. Power is 5kW.

● **HONDURAS**

R. Progreso, El Progreso, on **4920** at 0430, YL with songs in Spanish after station identification. Schedule is from 1100 to 2200 with a power of 1.5kW and from 2200 to 0530 with a power of 10kW.

Voz Evangelica, Tegucigalpa, on **4820** at 0250, religious programme in Spanish but also heard at 0415 identifying as "R. Capalito" with cuckoo calls repeated! Schedule is from 1000 to 0430 with English transmissions from 1500 to 1600 and from 0300 to 0430. Your guess is as good as mine!

● **NORTH KOREA**

Pyongyang on **6250** at 1958 when transmitting a tuning signal prior to the National Anthem and programme for South Korea which is scheduled from 2000 to 0930 and from 1500 to 1800, being noted on this channel since early April.

● **PAKISTAN**

Karachi on a measured **4736.5** at 0138, OM with songs in Urdu, local music with YL announcer. This is listed as the Foreign Service link to Islamabad, scheduled from 1830 to 2115 with a power of 10kW. Obviously operating an extended schedule.

Peshewar on **3330** at 1804, OM with the world news in Urdu. Schedule is from 1415 to 1810 for the afternoon/evening schedule and the power is 10kW.

● **AUSTRALIA**

Brisbane on **4920** at 0539, announcements and ballads in English, music in the Palm Court style. Schedule is from 1900 (Sundays 1930) to 1402 and the power is 10kW.

● **ZAIRE**

Kinshasha on **4880** at 2255, suprisingly enough a programme of European-style dance music, with announcements by YL in dialect. The schedule is on a 24-hour basis and the power is 10kW.

● **CAMEROON**

Yaounde on **4972** at 1940, local music in typical African style, complete with the throbbing beat of drums. Schedule is from 0500 to 0730 and from 1700 to 2300, the power is 30kW.

● **MALAWI**

Blantyre on **3380** at 2210, OM in vernacular with announcements, sign-off with National Anthem. Schedule is from 0257 to 0520 (from May to August 0257 to 1110 and from 1300 to 2210), from 1700 to 2210. The power is 100kW.

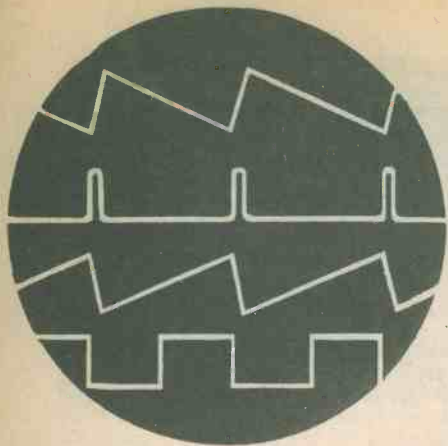

4-WAY BE

This unit allows the simultaneous presentation of four separate traces on a single oscilloscope screen. Switching from one trace to the next may be synchronised with the c.r.o. timebase, or it may be achieved by an unsynchronised chopping circuit. A switch is also provided which allows the circuit to split two waveforms only instead of four.

The oscilloscope beam splitter described here will convert many single beam instruments for multiple trace display without the necessity for internal modification. It was designed to be used with the 'Transistorised Oscilloscope' which appeared in the

December 1972 and January 1973 issues of *Radio & Electronics Constructor*. Results should be even better with the updated version of the oscilloscope (described in the September, October and November 1975 issues) since this includes d.c. coupling. Many commercial oscilloscopes have also proved suitable. The bandwidth of the beam splitter renders it unsuitable for certain radio and video applications.

PRINCIPLE OF OPERATION

A simplified diagram, Fig. 1, illustrates the principles involved. TR1 to TR4 are common emitter amplifiers, the collectors of which are supplied by a single resistor, R1. An electronic commutator connects each emitter resistor in turn to ground, whereupon the selected transistor amplifies the signal applied to its base, causing it to appear across R1. Since the emitters of the other three transistors are floating they act as reverse biased diodes to the signals applied to their bases, blocking the signal paths to R1 until they in turn are enabled. Pre-set variable resistors VR1 to VR4 are set so that the characteristic quiescent collector voltage of each transistor, when enabled, differs from the other three by a small increment. The resultant output from R1 will be a staircase waveform with the respective input waveforms of the four channels superimposed at their individual levels. The commutator can be advanced by a clock, or by the oscilloscope timebase flyback. In the latter case, there is one trace for each successive channel. Trace separation depends upon the standing collector voltage differences and the Y amplifier gain of the oscilloscope.

The gain of the beam splitter depends on the ratio of each emitter resistor to R1. This is set at 10 in the prototype but could be varied somewhat to suit individual requirements.

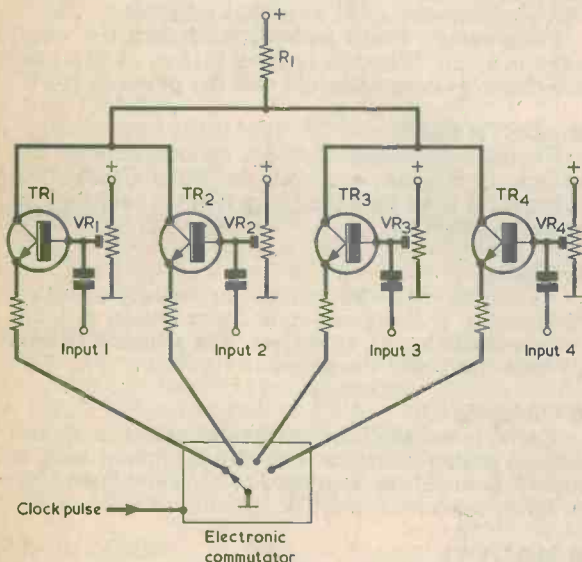
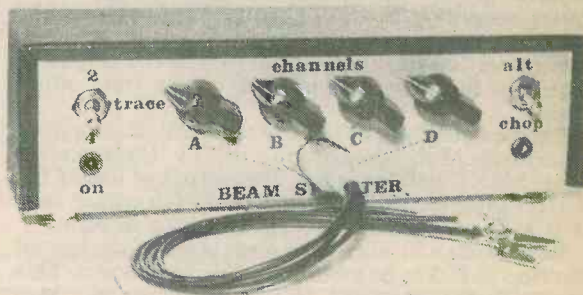

Fig. 1. Simplified diagram illustrating the operation of the beam splitter

BEAM SPLITTER

By B. Woodland and R. J. Woodland



COMPONENTS

Resistors

(All fixed values $\frac{1}{2}$ watt 5% unless otherwise stated.
See text concerning R27, R28 and R29)

- R1 10k Ω
- R2 1k Ω
- R3 100k Ω
- R4 8.2k Ω
- R5 1k Ω
- R6 100k Ω
- R7 8.2k Ω
- R8 1k Ω
- R9 100k Ω
- R10 8.2k Ω
- R11 1k Ω
- R12 100k Ω
- R13 8.2k Ω
- R14 5.6M Ω
- R15 2.2k Ω
- R16 5.6M Ω
- R17 2.2k Ω
- R18 5.6M Ω
- R19 2.2k Ω
- R20 5.6M Ω
- R21 2.2k Ω
- R22 390 Ω
- R23 2.7k Ω
- R24 560k Ω
- R25 100 Ω
- R26 2.7k Ω
- R27 82 Ω 1 watt (150 Ω 2.5 watt)
- R28 100 Ω (560 Ω)
- R29 1.2k Ω (1.8k Ω)
- VR1-VR4 5k Ω pre-set potentiometer, 0.1 watt, horizontal skeleton
- VR5-VR8 2.5k Ω pre-set potentiometer, 0.1 watt, horizontal skeleton
- VR9 2.2M Ω pre-set potentiometer, 0.1 watt, vertical skeleton
- VR10-VR13 2.2M Ω potentiometer, linear

Capacitors

- C1-C4 10 μ F electrolytic, 6 V. Wkg.
- C5-C9 0.1 μ F type C280 (Mullard)
- C10 0.047 μ F type C280 (Mullard)
- C11 1,000 μ F electrolytic, 25 V. Wkg.
- C12 220 μ F electrolytic, 16 V. Wkg.
- C13 100 μ F electrolytic, 16 V. Wkg.

Transformer

- T1 Mains transformer, secondary 8V 3VA (see text)

Semiconductors

- TR1-TR4 BC108
- TR5-TR8 2N3819E
- TR9 BC108
- TR10 BC108
- D1-D4 Silicon bridge rectifier, 1A 50PIV
- D5 5-1V zener diode, 1 watt
- D6 10V zener diode, 400mW
- D7 TIL209 or similar
- IC1 SN7413
- IC2 SN7473
- IC3 SN7400

Switches

- S1 s.p.s.t. toggle
- S2 d.p.d.t. toggle

Fuse

- FS1 250mA cartridge fuse, with panel-mounting holder

Sockets

- SK1 5-way 240° DIN socket
- SK2 Coaxial socket
- SK3 Coaxial socket

Miscellaneous

- Metal case (see text)
- Veroboard, 0.1in. matrix, 50 holes by 36 strips
- 4 pointer knobs
- 3-core mains lead
- Nuts, bolts, wire, etc.

COMMUTATOR

The full circuit diagram of the beam splitter appears in Fig. 2. A t.t.l. dual flip-flop is driven by clock pulses derived either from the oscilloscope flyback (the 'Alternate' mode) or by an internal clock built around a single Schmitt gate in IC1 (the 'Chopping' mode). The Chopping mode clock frequency depends mainly on the value of C9, although it also varies according to the switching thresholds of the Schmitt trigger used. In the prototype it was approximately 20kHz. The second gate in IC1 is used to speed up the edges of the clock pulses from either source.

The two bistables in IC2 are cascaded, their output binary codes being decoded to 1 of 4 by IC3, a quad 2-input NAND gate package. The output of one of the NAND gates will drop to ground for each output code of IC2, thereby enabling each transistor in turn.

Panel switch S1 allows the clear input of the second flip-flop in IC2 to be grounded, thus disabling it. This results in the provision of two output codes, these driving TR1 and TR2 alternately and producing two traces only.

For the present application the J and K inputs of IC2 should theoretically be tied to the positive rail by way of a limiting resistor. In practice, however, the i.c. functions quite satisfactorily with the J and K inputs open, as the inputs themselves then take up a positive 1.

CHOICE OF MODE

With the Alternate mode selected, a whole sweep of the timebase is used for each trace. The Chopping mode samples a small portion of each input waveform in turn, a large number of the samples building up a picture of the four input waves during a single timebase sweep.

Alternate mode operation is usually preferable, since trace resolution is superior. There are, however, two instances where better performance is possible with the Chopping mode. The first instance occurs at low sweep frequencies with a.c. coupled oscilloscopes, where trace drift appears due to an input coupling capacitor of too low a value. The second instance is given at very low sweep speeds with which the first trace, on Alternate mode, would have faded before the last trace is drawn.

ALTERNATE MODE CLOCK SIGNAL

During Alternate mode operation the commutator clock pulse is supplied by the timebase ramp output socket, which is found on the back of most oscilloscopes. It is not possible to use the ramp output directly, since its voltage and impedance will be too high. Accordingly, TR9, TR10 and their associated circuitry are interposed, performing the necessary

transformation of voltage and impedance.

Pre-set potentiometer VR9 allows the correct input level to be selected. Its high resistance and the high input impedance of the emitter follower, TR9, prevent undue loading of the oscilloscope ramp output. TR10, a common emitter amplifier, raises the output to a suitable level, speeds up the pulse edges, and performs the necessary polarity inversion for driving the Schmitt trigger input in IC1.

S2(a) (b), a double pole changeover toggle switch, connects the input of the amplifier formed by TR9 and TR10 to the beam splitter ramp input socket, SK3. At the same time, its other pole grounds an unused input of the Schmitt trigger pulse generator, disabling the latter. This switch thus allows selection of either Alternate or Chopping mode operation.

INPUT BUFFERS

The input impedances of the four channel amplifiers, TR1 to TR4, are at some 10k Ω or less. Naturally, it is desirable to have input impedances considerably higher than this to prevent loading of test circuitry. Accordingly, each of the transistors is preceded by an f.e.t. source follower, the input impedance of which is in the order of megohms. The 2.2M Ω potentiometers, VR10 to VR13, provide variable input attenuation for each f.e.t.

Because of the wide variation in characteristics of f.e.t.'s of the same type, variable source resistors VR5 to VR8 are provided, these being adjusted to give half the supply voltage across each f.e.t.

The f.e.t.'s employed in the prototype are 2N3819E (available from Trampus Electronics, Ltd., 58-60 Grove Road, Windsor, Berks.). These are preferred to the standard 2N3819 because the gate lead is distal from the source lead, thereby providing effective isolation of output and input and relief from cramping on the component board to which the f.e.t.'s are fitted.

SYNCHRONISATION

With Chopping mode operation the oscilloscope's internal sync may not be used since it would latch onto the dominant input, the staircase switching waveform. Whilst it would be possible to use internal sync for Alternate mode operation, this would only be possible when all four (or both in 2-trace mode) inputs are supplied. It is suggested that external triggering be utilised, this being derived from a suitable point in the test circuitry.

BLANKING

The beam splitter is designed so that the Chopping mode needs to be used only at low scan speeds, whereupon it is possible to employ a relatively low chopping frequency. Consequently, blanking of the switching transients should be unnecessary, thereby eliminating the necessity for a third lead between oscilloscope and splitter.

POWER SUPPLY

The demands of the circuitry are modest, these being 5 volts at less than 50mA for the logic i.c.'s, and 10 volts at a few milliamps for the amplifiers. The latter will function quite satisfactorily at any voltage between 10 and 15 volts.

The 8 volt r.m.s. output of a small mains isolating transformer, T1, is rectified by diodes D1 to D4 and smoothed by reservoir capacitor C11, providing a d.c. voltage between 11 and 12 volts. This powers two



The controls on the front panel of the beam splitter are positioned in a neat symmetrical manner

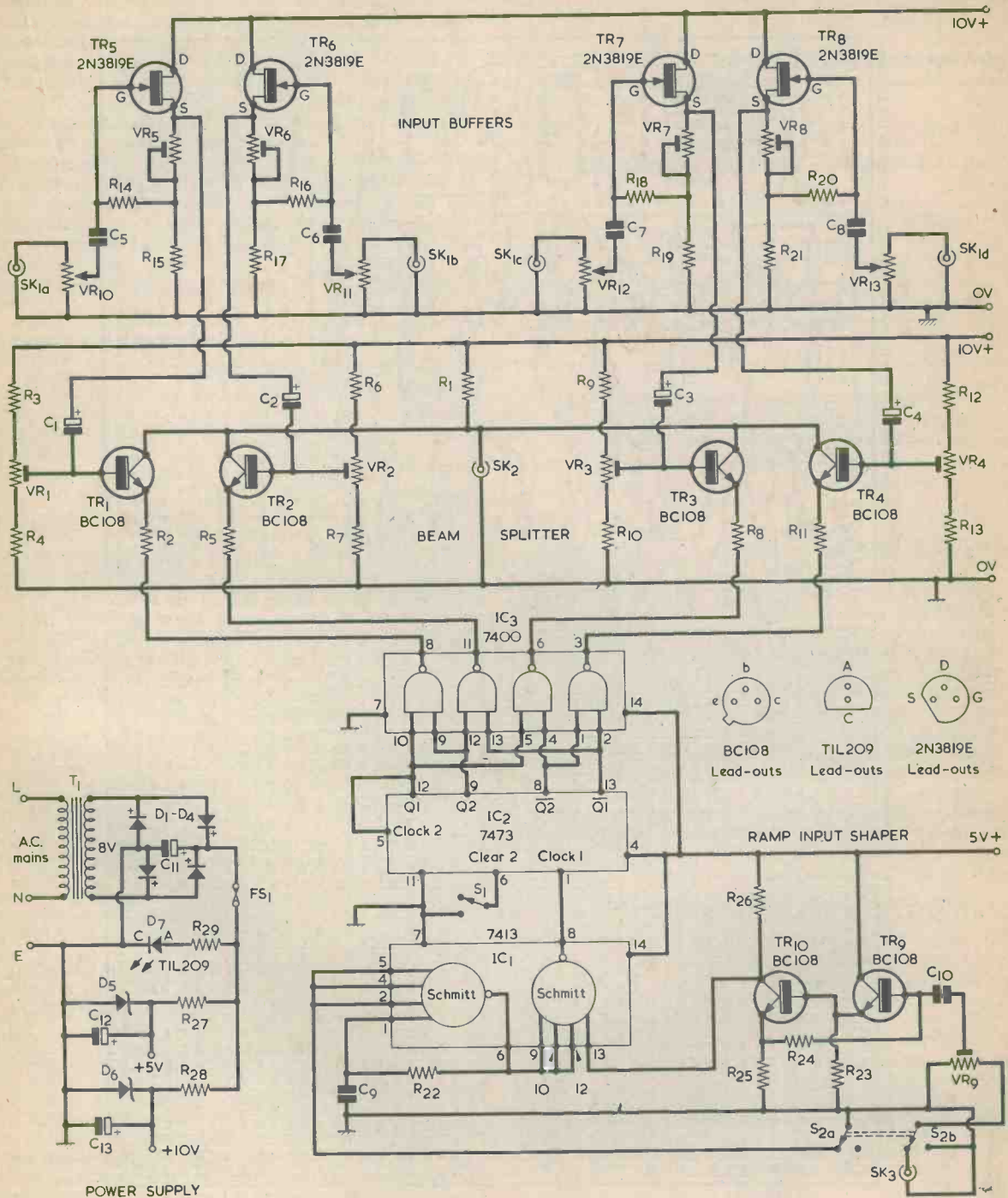

Fig. 2. Complete circuit diagram for the 4-way beam splitter.

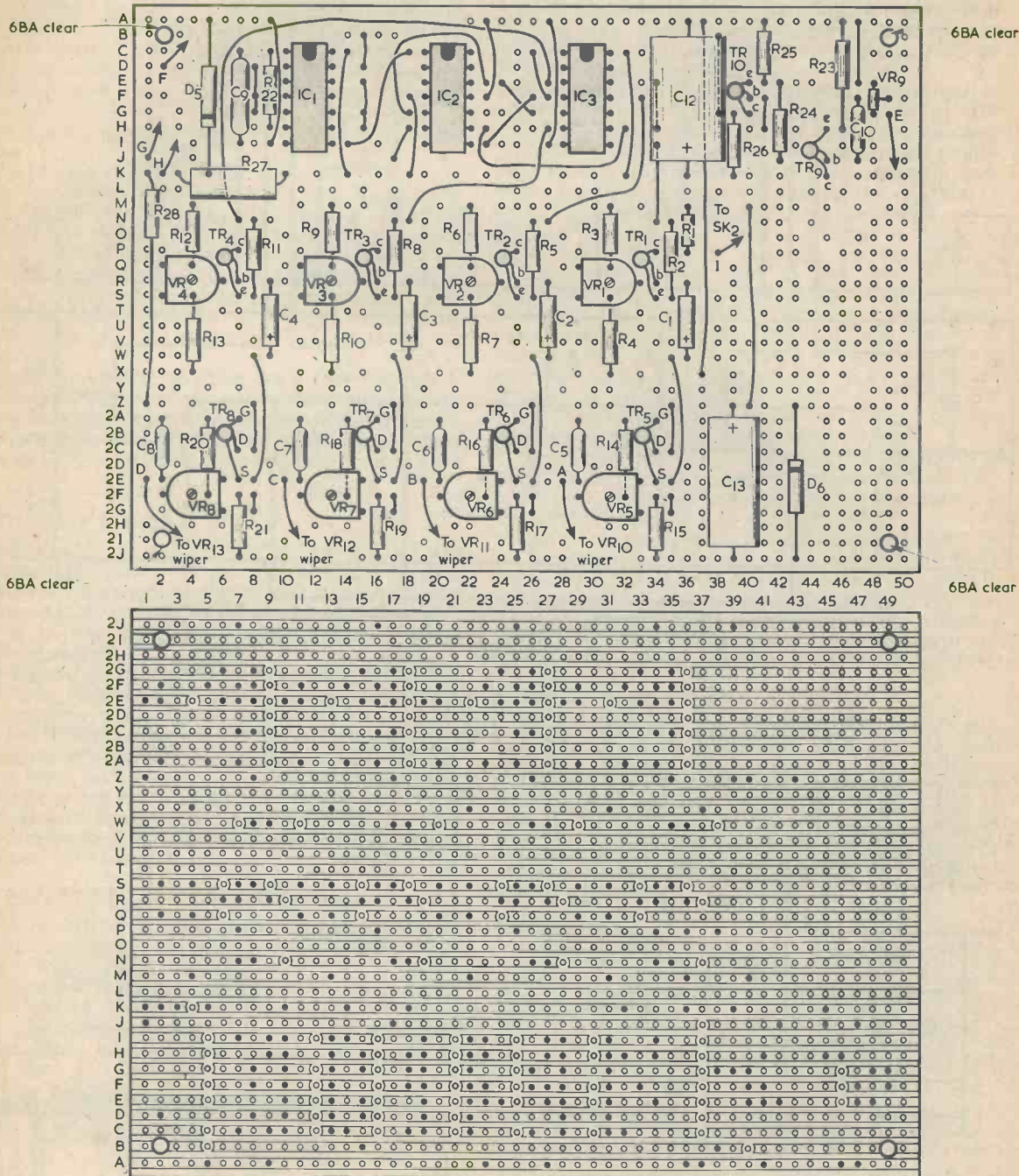

Fig. 3. The component and copper sides of the Veroboard panel.

zener diode stabilizers: R27, D5 and C12 for the 5 volt logic supply, and R8, D6 and C13 for the 10 volt transistor supply. Fuse-link FS1 prevents overload of the transformer secondary.

No mains on-off switch is provided in the unit, with the result that the internal mains wiring and the likelihood of 50Hz hum pick-up by the amplifiers are kept to a minimum. A panel-mounted light-emitting diode, D7, is wired across C11, and indicates that the unit is on. Current through the l.e.d. is limited to about 10mA by series resistor R29.

The component employed in the prototype for T1 is a Friedland bell transformer with a secondary rating of 8 volts at 3VA. If difficulty is experienced in obtaining this, a small mains transformer with a secondary offering 12 volts r.m.s. at 150mA or more may be substituted. R27, R28 and R29 are then given the higher values shown in brackets in the Components List.

CONSTRUCTION

The main circuit board consists of 0.1in. matrix copper-clad Verboard, and employs the layout shown in Fig. 3. Preferably, sockets should be used for the integrated circuits. Veropins, or Soldercon i.c. pin sockets, may be employed to connect flying leads. These are not essential but they considerably assist in the final assembly. VR1 to VR8, the horizontal skeleton potentiometers fitted to the board, should have 0.2in. spacing between track tags and 0.4in. spacing between slider and track tags. The vertical skeleton potentiometer, VR9, requires 0.2in. spacing between track tags and 0.1in. spacing between slider and track tags.

All board wiring is carried out with thin, p.v.c. covered, single-strand wire. The input and output leads could be screened, but this proved unnecessary in the prototype due to the overall layout, and the shortness of the leads. If alternative layouts are used it would be wise to employ screened cable.

The unit should be assembled in a metal case, and the case type BV4 available from Bi-Pak, which measures 9 by 5½ by 2½in., will be suitable if the Friedland mains transformer is employed. This case should also accommodate alternative transformers provided these are not excessively large.

Drilling details for the front and rear panels (assuming these are 9 by 2½in.) are given in Fig. 4. The front panel is drilled to take input attenuators VR10 to VR13, S1, S2, the l.e.d., and a 240° 5-way DIN input socket, SK1. (An extra hole, fitted with a grommet, is visible in the photograph of the front panel. This hole is not used for any function). On the back panel are mounted the fuse, output socket SK2 and ramp input socket SK3. There is also a hole, with grommet, for the mains lead.

Further wiring details appear in Figs. 5 and 6. T1, C11 and the bridge rectifier, D1-D4, are positioned on the chassis as shown. The circuit board is spaced off from the chassis by extra nuts on the four 6BA bolts which secure it. The copper strips on or adjacent to the mounting holes take up chassis connections from these nuts. If desired, small plain washers may be fitted between the nuts and the strips to ensure a good connection. A solder tag is secured above the board under one of the board securing nuts in the position shown in Fig. 5, and this provides a chassis connection for the front panel components and the power supply

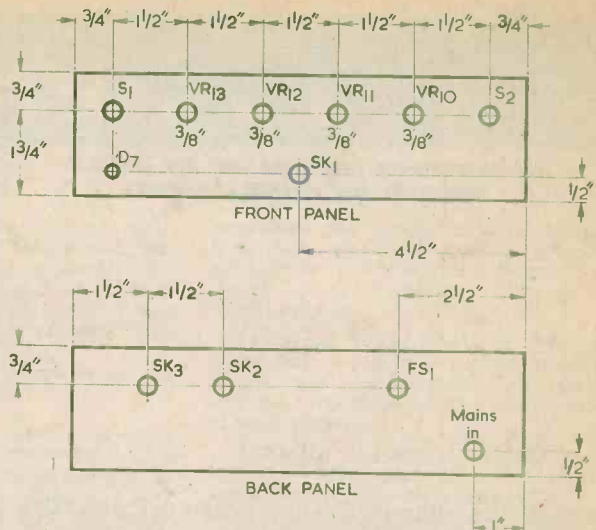

Fig. 4. How the front and back panels are drilled. Hole diameters are not shown where these depend on the particular components employed

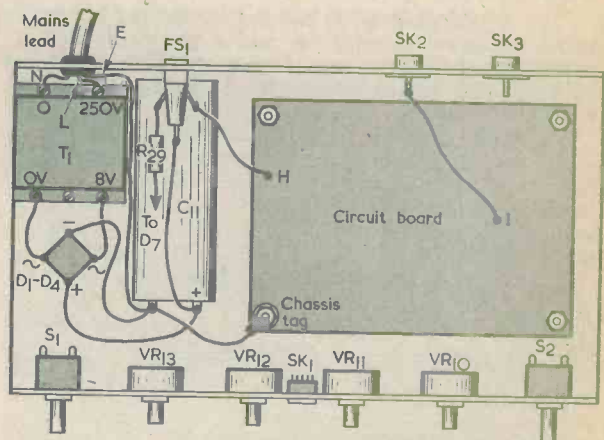

Fig. 5. Wiring up the power supply components external to the board. Also shown is the connection to SK2

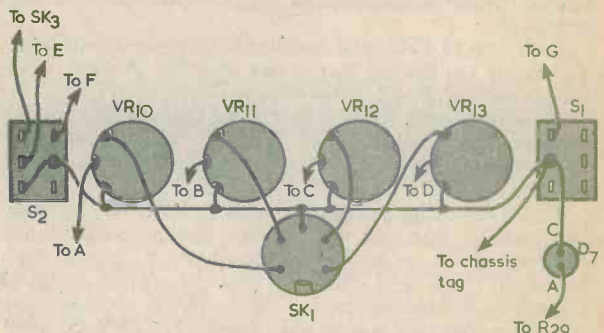
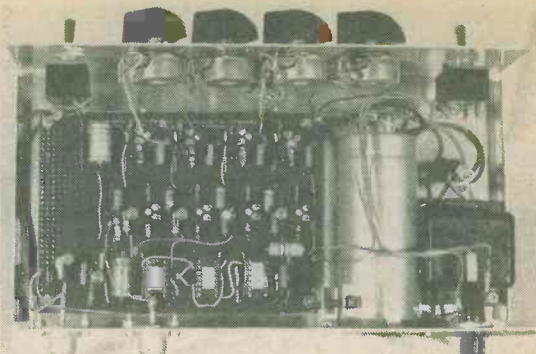

Fig. 6. The wiring to the controls and the input socket on the front panel

The components inside the unit are laid out compactly and without crowding



section. The mains earth wire connects to the negative tag of C11.

Four rubber feet are mounted near the corners of the chassis on the underside. These are secured in place with adhesive.

SETTING UP

The only instruments needed for setting up are a small insulated screwdriver and a voltmeter with a sensitivity of 10,000 Ω per volt or more. This is switched to a range which offers useful readings around 5 volts.

No connections are made to the oscilloscope at this stage. Switch on the beam splitter and set S2 to the Alternate mode. Carefully adjust VR5 for a 5 volt reading between TR5 source and chassis. Repeat for 5 volt source readings with VR6 for TR6, VR7 for TR7 and VR8 for TR8.

Connect the voltmeter between chassis and the lead of R2 which connects to IC3. If the voltmeter indicates zero volts or a fraction of a volt, this means that TR1 is enabled. If, on the other hand, a reading of between 3 and 4 volts is given, turn S2 to Chopping mode then back to Alternate mode. Repeat this process as often as is necessary to obtain the low voltage reading that indicates that TR1 is enabled. Then connect the voltmeter across R1 and adjust VR1 for a reading of 5 volts.

Next connect the voltmeter between chassis and the lead of R5 connecting to IC3, then operate S2 as before until TR2 is enabled. Adjust VR2 for 4.8 volts across R1.

Carry on to TR3, and enable this transistor with the voltmeter connected to chassis and R8. Adjust VR3 for a reading of 4.6 volts across R1.

Finally enable TR4, with the voltage on R11 as indicator, then adjust VR4 for 4.4 volts across R1. Remove the voltmeter and switch off the beam splitter.

Put VR9 to its minimum setting, with its slider at the earthy end of the track. Make connections between SK2 and the oscilloscope Y input, and between SK3 and the oscilloscope ramp output. Switch to Chopping mode. Turn on the oscilloscope, selecting free-run, a slow scan speed (e.g. 200mS) and, if possible, d.c. coupling. Now switch on the beam splitter and increase oscilloscope gain until four well separated traces are obtained. It may be necessary to

slightly readjust VR1 to VR4 to obtain equal trace spacing.

Next, switch the beam splitter to the Alternate mode then slowly and carefully adjust VR9 to the lowest setting capable of producing four traces. Take care to use the insulated screwdriver, and avoid touching its metal shaft during this operation, since the ramp peak voltage may approach 100 volts. It should be remembered that if an a.c. coupled oscilloscope is used the traces will tend to converge towards the ends of the scan at low timebase frequencies. This is why the Chopping mode was incorporated.

The beam splitter is now set up and ready for use. VR9 must, however, be readjusted if the unit is employed with another oscilloscope. VR9 should always be initially put to its minimum setting before commencing readjustment. The 200mV trace separation may be decreased if it is desired to increase the input sensitivity. The voltage separation must not be increased excessively or distortion may result.

UNSUITABLE OSCILLOSCOPES

In the event that there is no ramp output socket on the oscilloscope one must be provided. The provision of a ramp output should only be attempted by the constructor who understands exactly what he is about, and it is beyond the scope of this article to provide adequate instruction here. It will often be found that a suitable ramp for driving the beam splitter may be obtained from the X amplifier input socket when the timebase is running.

It would be possible to dispense with the Alternate mode and have the beam splitter operate in the Chopping mode only. S2 could then be wired so as to switch a different value of C9 into circuit so that two clock frequencies are available. The performance of the splitter would then, however, be somewhat inferior.

PROBES

The most versatile signal input probe arrangement consists of a 5-way DIN plug to which are soldered four thin screened leads, these terminating in small crocodile clips. The junctions between leads and clips are bound with short lengths of p.v.c. covered wire, a different colour being used for each lead. The coloured wires not only identify the channels but also strengthen the joints. ■

Trade News . . .

DORAM'S RADIO MODULE RANGE



The 432MHz Converter designed and manufactured by Microwave Modules. This is part of the new Radio Module range available ex-stock from Doram

Doram Electronics Limited, mail-order distributors of components, kits and accessories for amateur electronics, radio and hi-fi enthusiasts have introduced new top quality Radio Modules to their wide range of radio accessories.

Designed and manufactured by Microwave Modules Limited, the range includes:

144MHz Converter — designed to convert the two-metre band to a convenient coverage range suitable for shortwave receivers. The two-metre band (144-146MHz) may be covered in either tuning range 28-30MHz or 2-4MHz. Both are priced at £15.25.

70cm-432MHz Converter — will convert the 70cm band down to 2 metres or 10 metres. Two R.F.

amplifiers and a Mosfet mixer combine high sensitivity and low-cross modulation characteristics. Price IF output — 144-146MHz £18.25; 28-30MHz £18.25.

144MHz Dual Output Pre-amplifier — £9.25 — a two stage Mosfet pre-amp module with two isolated outputs to improve reception of weak signals.

432MHz Varactor Tripler — £17.65 — offers high efficiency with excellent harmonic suppression. Up to a 20 Watt 144-146MHz input signal may be used to give up to 14W output on 70cm, AM, FM or CW.

All Radio Modules listed are available ex-stock and are subject to 12½% VAT.

VERO ELECTRONICS FULLY OPERATIONAL AT BARTON PARK

Vero Electronics Limited have now become fully operational at their centralised Stores and Dispatch Unit at Barton Park Industrial Estate, Eastleigh, Hants. The move to this 20,000 square feet specially equipped warehouse is designed to further improve and guarantee rapid delivery and ex-stock availability of all products manufactured and supplied by the Company.

The main Stores area utilises purpose built storage units with palletisation and a special stacking forklift truck (see photograph) for rapid movement of bulk supplies. Day-to-day shipments take place from a smaller stores area which has been laid out for optimum access when withdrawing small quantities of a large number of different items.

This Stores and Dispatch facility has been designed with expansion in mind. It therefore readily copes with the thousand individual shipments per week currently made to all types of U.K. customers

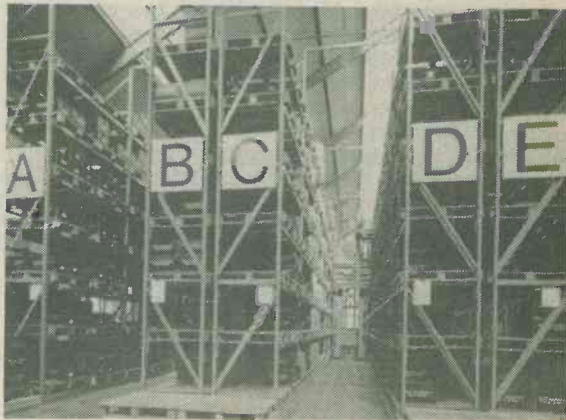

together with export consignments to three Subsidiary Companies and twenty-five overseas Agents.

D.I.Y. BURGLAR ALARM KIT



Messrs Antex, of Mayflower House, Plymouth, Devon, have launched what is believed to be the first D.I.Y. burglar alarm kit which complies with the strict standards of B.S.4737.

The illustration shows the control box of the battery-operated version (Model A 1 B). The mains-operated Model A 1 MB is suitable for the average 3 bedroomed house.

The electronic circuitry which provides the owner with a variety of useful facilities is housed in a strong, tamper-proof steel box. Special precautions were taken to prevent false alarms, the bane of so many alarm systems.

Recommended retail prices exclusive of V.A.T. Model A 1 B £50, Model A 1 MB £74.

ONE VALVE WORKING ON '160' AND '80'

by A. S. Carpenter

Expensive commercial equipment is not necessary for putting out a c.w. signal on 160 and 80 metres, as this article clearly demonstrates. The transmitter described must, of course, be operated only by constructors having the requisite licence.

Amateur band working has in recent years been made so simple with the availability of sophisticated commercially produced equipment that it can be refreshing to experiment with less ambitious apparatus. Commercial gear is by no means inexpensive and many would-be enthusiasts are without doubt deterred by this fact. The simplicity of the small transmitter to be described — made to prove that Amateur participation need not be an expensive pastime — is appealing in that it costs but little to construct and can be put together in quite a short time. Some of the component values need a little experiment for optimum results, but the fact is that the rig works well and attracts T9 reports. Indeed, when fed into the station 150ft. end-fed antenna surprisingly good reports came in, resulting in some pleasing log entries.

Detailed constructional information on the transmitter will not be given as it is intended to be built by experienced licenced amateurs.

CIRCUIT DESIGN

The transmitter was originally assembled for operation on the 160 metre band only. The circuit for the transmitter in this form is given in Fig. 1, where it will be seen that a single ECL83 has its triode section employed as a crystal oscillator and its pentode section as the p.a. stage. This particular valve type is useful in Amateur transmitting applications and has been found to work well even at 2 metres. An ECL 80, which has a single common cathode for triode and pentode, has also been tried, with keying in the cathode circuit. This, however gave rise to "chirp". No "chirp" is evident with the ECL83, because its separate cathodes permit keying in the p.a. stage only.

Because "Top Band" is a shared band complaints of QRM are frequently heard from Amateur operators. Not all gear in use is drift-free, and unfor-

tunately some transmissions suffer as a result. Crystal control ensures non-drifting and enables the user to slot his transmission into the few available band gaps that are free of QRM. Provided that both he and his partner in the QSO have reasonably good receivers communication can usually be maintained in unfavourable circumstances, particularly if both are using the unbeatable transmission mode of c.w. The merits or otherwise of the alternative operating modes will not be discussed here except to note the fact that, with c.w., a high selectivity receiver with perhaps an added audio filter can give what is virtually single signal reception.

With V1(a) functioning as a simple crystal controlled oscillator it is found that V1(b) receives good drive via a pi-network. The drive can be monitored by a testmeter connected between chassis and test point TP1. The pentode feeds into the antenna via another pi-network.

A "Net" position is hardly required at the Function switch. Nevertheless, one is included since it is still helpful on occasion to be able to check the operating frequency on the station receiver; the same switch controls both the h.t. and aerial connections. Resistor R8 is included to ensure adequate h.t. loading of the external power supply when "Net" and "Receive" are selected. If this resistor were omitted the supply voltage might rise to an undesirably high level, with consequent strain on the smoothing capacitors. The power supply should be capable of providing 250 volt h.t. at 60mA and 6.3 volt a.c. at 600mA.

A permanent meter is not fitted since few if any changes to loading or tuning are required once the transmitter has been initially set up. Voltage checks can be made to test point TP2 or TP3, whilst current measurements may be made by removing the link between these two points and inserting a testmeter switched to a suitable current range.

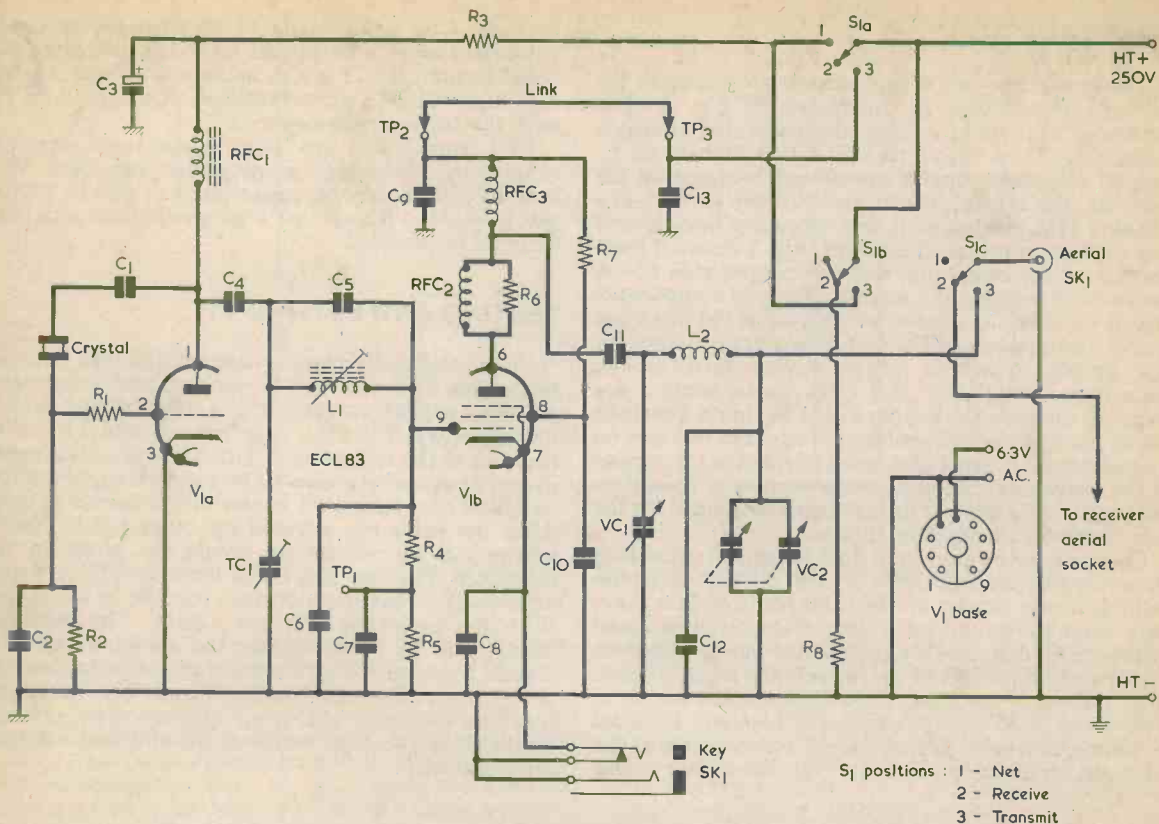

Fig. 1. The circuit of the one-valve transmitter when wired up for operation on 160 metres

COMPONENTS

Resistors

All $\frac{1}{4}$ watt 10% unless otherwise stated)

- R1 15 Ω
- R2 33k Ω
- R3 1k Ω
- R4 22k Ω
- R5 1k Ω
- R6 68 Ω 1 watt
- R7 15k Ω $\frac{1}{4}$ watt
- R8 12k Ω $\frac{1}{8}$ watt

Capacitors

- C1 1,000pF silvered mica
- C2 25pF silvered mica
- C3 4 μ F electrolytic, 350V Wkg.
- C4 100pF silvered mica
- C5 see text
- C6 220pF silvered mica
- C7 1,000pF feed-through
- C8 0.01 μ F ceramic
- C9 1,000pF feed-through
- C10 5,000pF ceramic
- C11 1,000pF ceramic
- C12 470pF silvered mica
- C13 1,000pF feed-through
- VC1 see text
- VC2 500+500pF variable, 2-gang
- TC1 60pF trimmer, mica

Inductors

- L1, L2, L3 see text
- RFC1 2.5mH r.f. choke type CH1 (Repanco)
- RFC2 see text
- RFC3 2.6mH r.f. choke type RFC.9A (Denco)

Valve

- V1(a)(b) ECL83

Switches

- S1(a)(b)(c) 3-pole 3-way rotary
- S2(a)(b) d.p.d.t. slide, miniature

Sockets

- SK1 coaxial socket
- SK2 $\frac{1}{4}$ in. jack socket with break contact

Miscellaneous

- Crystals, HC6/U, as required
- Crystal holder, HC6/U
- Valveholder, B9A
- 5-way tagstrip
- Copper-clad laminate
- Aluminium sheet (for front panel)
- 3 knobs
- Wire, nuts, bolts, etc.

CONSTRUCTION

The general layout of components employed in the author's transmitter is illustrated in Fig. 2. The "chassis" consists of a piece of copper-clad laminate measuring 7 by 3¼ in., to which is attached an L-shaped aluminium panel on which are mounted the controls, the crystal holder and the key socket. The panel is 1½ in. deep, and it may of course be deeper if any of the controls warrants this. Fig. 2 shows the underside of the assembly, and the copper side of the laminate is towards the reader. The only components visible on the other, upper, side are SK1, the three test points and the valve. The test points are provided by the simple expedient of employing feed-through capacitors for C7, C9 and C13. Earth returns are soldered direct to the copper of the laminate. Both pin 4 and pin 5 of the valveholder are wired to two tags on a small tagstrip, pin 4 also being earthed to the copper at the valveholder. The tagstrip couples to the external supply, two more of its tags being employed for the h.t. positive and negative inputs.

Coil L1 may be any small dust-cored coil capable of resonating around 1.8MHz in the circuit. If home-wound, it can consist of about 80 turns of thin d.s.c. wire scramble-wound on a ¼ in. diameter dust-cored former. The coil used by the author was of unknown origin and, since it had an inductance slightly lower than the value required, C5 was connected across it. This was a 30pF Philips concentric trimmer. It would be better, however, to fit a coil which resonates at the required frequency without C5, the latter being

omitted. Coil L2 consists of 60 turns of 26 s.w.g. enamelled wire close-wound on a 1 in. diameter air-cored former. RFC2 is also home-wound and consists of 8 turns of 26 s.w.g. enamelled wire wound on R6 with the turns slightly spaced.

VC1 and VC2 are both air-spaced variable capacitors of the type employed in receivers. VC1 may have a maximum capacitance of 200 to 330pF, whilst VC2 is a 500+500pF 2-gang capacitor with both sections in parallel.

TESTING AND SETTING UP

For initial testing and setting up, the link between test points TP2 and TP3 is removed and a testmeter switched to read currents of the order of 2mA is connected between the h.t. negative rail and TP1, with negative to the test point. A suitable crystal is plugged in and S1 set to "Receive". The external supply unit is switched on, causing V1 heater to commence to glow. After the valve has warmed up, S1 is put to "Net", whereupon an indication should be given in the testmeter. The core of L1 and trimmer TC1 are then adjusted for maximum current reading in the meter. With the prototype this was 1.8mA. The oscillator should also be picked up by the station receiver at crystal frequency. The Function switch is next moved several times between "Receive" and "Net" to ensure that the oscillator starts up quickly. The external power supply is then switched off and the testmeter disconnected.

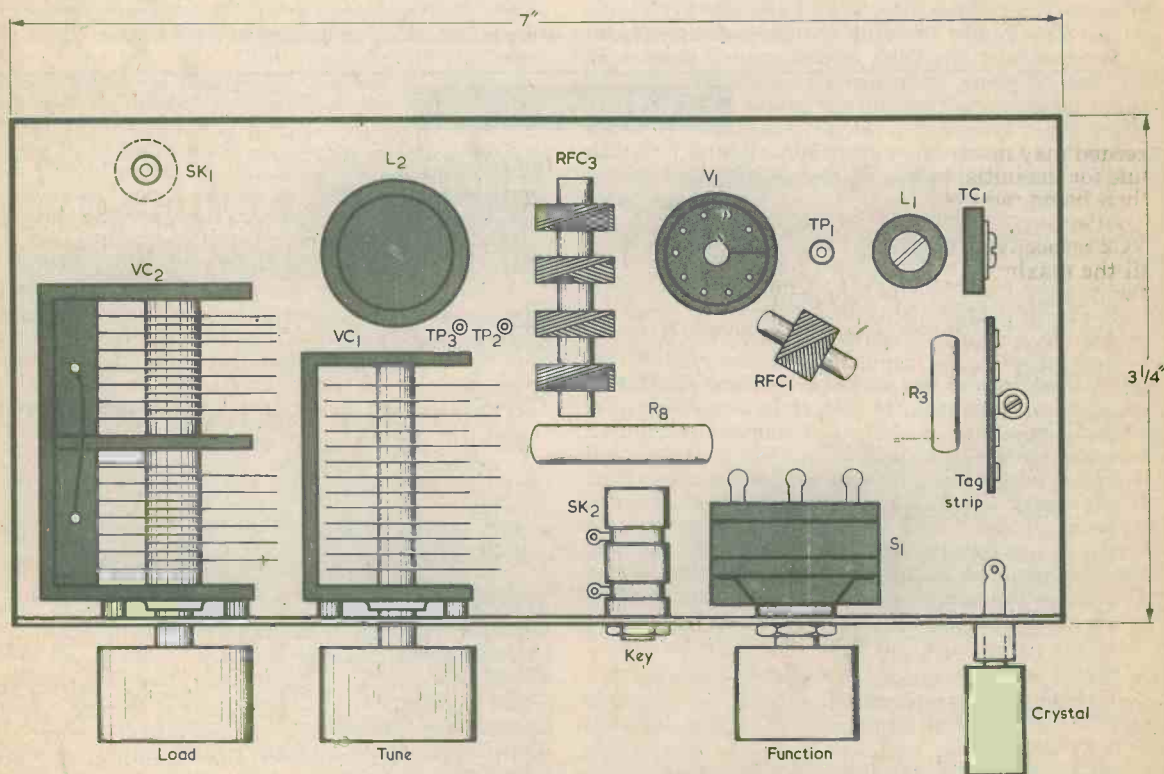

Fig. 2. General layout of the principal components in the transmitter. Further details are given in the text

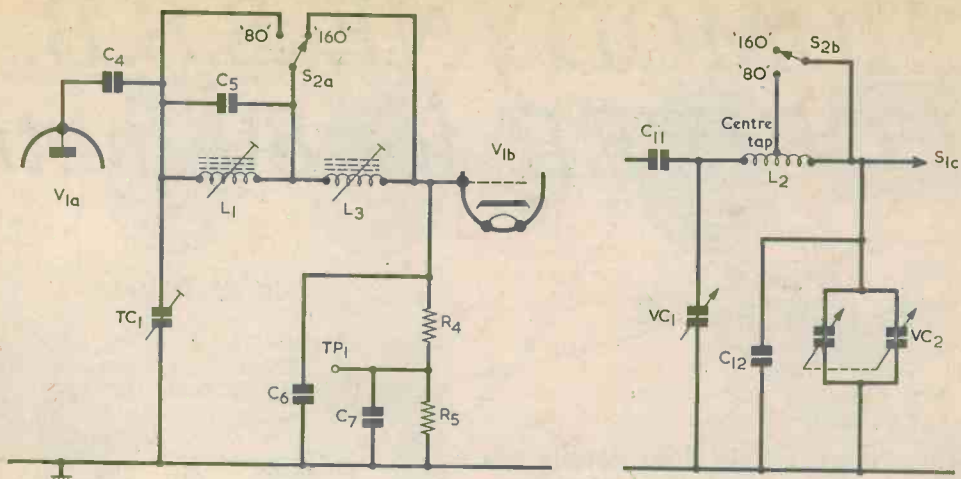

Fig. 3. The switching circuits which are added for operation both on 160 and on 80 metres

The testmeter is next switched to read currents around 60mA and is connected to TP2 and TP3 with positive to TP3. A 75 Ω dummy load is connected to SK1. Capacitors VC1 and VC2 are both set to full capacitance and S1 to "Receive". The external power supply is again switched on and V1 allowed to warm up. Keeping one hand on VC1 knob, the Function switch is set to "Transmit". This will cause a reading of some 50 to 60mA to be given in the meter and VC1 is quickly adjusted until this current indication falls to a lower value. Quick adjustment of VC1 is desirable to avoid excessive dissipation in V1(b). The maximum rated cathode current for the pentode is 45mA and those who would prefer to ensure that this is not exceeded may insert series resistance in the h.t. positive line for the initial setting of VC1, the series resistance then being removed.

After this, tuning and loading by way of VC1 and VC2 respectively is carried out in normal manner until the maximum available r.f. output is being fed to the dummy load. Should it be found that VC1 cannot provide sufficient capacitance for the final adjustments, a small value fixed capacitor may be connected across it. The frequency stability can be checked by inserting the key at socket SK2 and listening on the station receiver, the latter having been made suitably insensitive (as it will also have to be during later use of the transmitter).

Subsequently, the power supply is switched off and the testmeter and dummy load removed. The link between TP2 and TP3 is then fitted. With a suitable aerial connected, preferably via an aerial matching unit, any small re-adjustments to tuning can be made with the r.f. output visually monitored by means of either an r.f. ammeter, a wavemeter or an s.w.r. indicator.

ADDING 80 METRES

The modification needed for adding the components for 80 metre operation is of a minor nature and no extensive rebuilding is required. Basically, the

changes involve making a centre tap in L2 and introducing a separate 80 metre coil between V1(a) and V1(b). The appropriate switching can be carried out with a small d.p.d.t. slide switch, and in the author's transmitter this is located near the valveholder. Also required is a crystal having a frequency in the 80 metre band, say from 3,502 to 3,600 kHz. Frequency doubling from the 160 metre crystal may result in insufficient drive and in any case some of the doubled 160 metre frequencies would not be suitable for 80 metre requirements.

The switching circuitry required is shown in Fig. 3. As may be seen, S2(a) of the slide switch short-circuits L1 on "80" and short-circuits the new coil, L3, on "160". S2(b) short-circuits half of L2 on "80" and leaves the whole coil in circuit on "160". Out of various switching arrangements tried this has proved most satisfactory in practice because of its simplicity and the fact that unwanted inductance on either range is completely short-circuited.

L3 should resonate in the circuit at around 3,550kHz and, if home-made, may consist of some 50 turns of thin d.s.c. wire close-wound on a $\frac{1}{4}$ in. diameter dust-cored former. A little "cut and try" is usually inevitable with home constructed transmitters of this nature, and some adjustment to L3 turns may be required to make it resonate at the desired frequency with the same setting of TC1 that is applicable for L1. A parallel capacitor could be fitted across the coil, as with C5 across L1, but this is best avoided if possible. A g.d.o. will cause much time to be saved when making the new coil.

Setting up, tuning and loading is the same as for 160 metres, and the current reading between TP1 and the h.t. negative line should be about 2mA.

The Components List includes the parts required for the modification. These will not be needed if it is intended to use the transmitter on 160 metres only.

In conclusion it can be truthfully said that a lot of fun can be had from making and operating simple rigs of the type described here. This is additional to proving that participation in Amateur radio need not be a costly occupation at all. ■

HOMODYNE S.S.B. RECEIVER for 80 metres

Part 2
by R. A. Penfold

In this concluding article final details are given for wiring up the receiver. Also dealt with are its setting up and operation, together with a simple modification which permits reception on the 40 metre band.

In last month's issue the circuit of this unconventional receiver was described, after which details were given of chassis preparation and the assembly of the component panel. We now carry on to the remaining constructional steps.

GENERAL WIRING

Before wiring commences, two 6BA clear holes are drilled in the bottom of the case to allow the component panel to be mounted. The holes are marked out with the aid of the panel itself, and the position it takes up can be seen from the photographs of the interior. The precise position taken up by the panel is not particularly critical. Spacing washers over the two 6BA mounting bolts keep the panel underside spaced away from the bottom of the case. Added protection against short-circuits here may be given by applying plastic insulating tape over the area of the case bottom which is below the panel.

The controls and sockets are next mounted on the front and rear panels.

Fig. 7 illustrates the wiring at the controls and at the B9A valveholders into which the two coils are plugged. Wires having letter and number references are those from the corresponding points of the component panel.

A number of components are wired directly to the valveholder tags, as shown. Note that there is a solder tag under one of the securing nuts for each valveholder. The two ceramic trimmers, C1 and C13, are soldered directly to the valveholder tags. If tag positioning does not allow this, the connections are made by means of very short lengths of stout wire. This method of mounting imparts rigidity to the trimmers and enables them to be adjusted.

The junction of the two batteries connects to the earthy tag of VR1 and then to jack socket SK3. The latter provides the chassis connection which is required here by way of its mounting bush and nut. If



the socket to be used has an insulated construction which does not provide this chassis connection, a 6BA solder tag may be fitted at an adjacent point on the bottom of the case, and the chassis connection taken from this.

The interconnecting wiring should be kept reasonably short. Most of the wiring is either at low impedance r.f. or a.f., or is virtually of a d.c. nature. The relatively long leads from VR2 slider to the variable capacitance diodes are quite in order due to the presence of the series decoupling resistors, R7 and R15, at the diodes themselves. The wiring to the diode anodes causes no problems in practice.

There is plenty of space behind SK3 and VR3 for the two batteries, these being positioned vertically. A simple clamp may be devised to hold them in place. Another approach consists of affixing foam plastic or rubber to the undersurface of the case lid above the batteries. This will hold the batteries in position when the lid is fitted to the case.

ADJUSTMENTS

L1 and L2 are provided with iron-dust cores which are fully screwed into the coils as supplied. The core of L1 is unscrewed so that about $\frac{1}{4}$ in. of the brass thread protrudes from the top of the coil former, and that of L2 is unscrewed so that about $\frac{1}{4}$ in. is showing.

The receiver can then be turned on and an aerial, earth and headphones or earphone connected to the appropriate sockets. It should be possible to tune in a few stations by means of VR2, whereupon adjustments to C1 and the core of L1 should enable these to be peaked.

If an accurately calibrated signal generator is available, it is a simple matter to adjust C13 such that the receiver covers the band from 3.5 to 3.8MHz. The core of L2 should only be adjusted if necessary. In the absence of a signal generator it is possible to use amateur transmissions for the determination of band

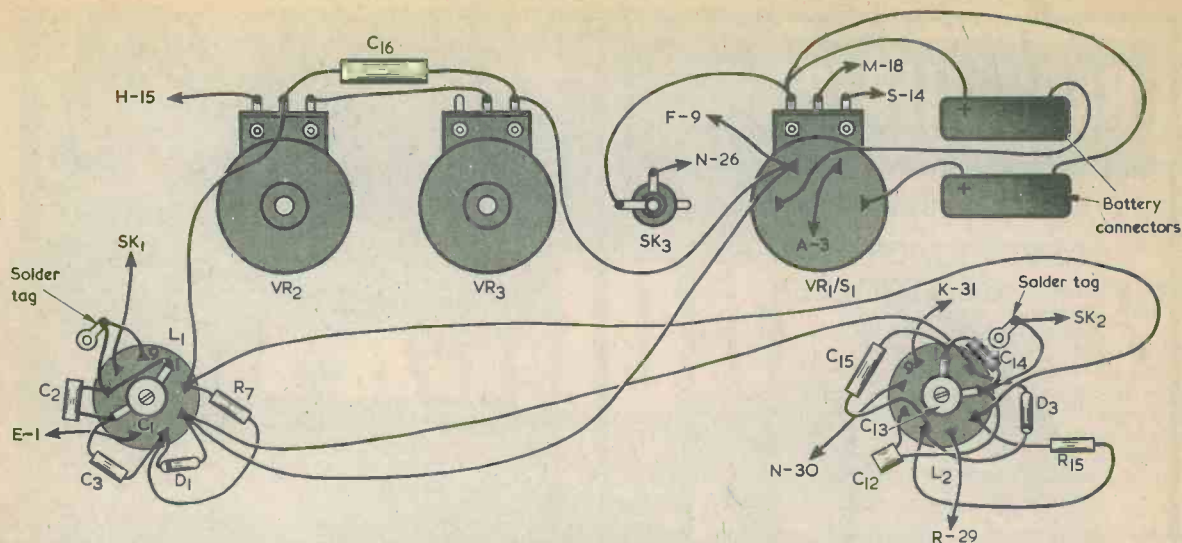

Fig. 7. Wiring to the controls and coils in the homodyne receiver. The letter and number references apply to the component panel, the layout drawing of which was published last month

limits, and it is best to choose a time when a lot of amateurs are likely to be on the air. During evenings and week-ends the 80 metre band is normally very crowded, and the band limits are usually fairly obvious. It should be remembered that the low frequency end of the band (corresponding to VR2 spindle turned well in the clockwise direction) is reserved for c.w. signals.

By this means it is a matter of adjusting C13 and the core of L2 so that all the transmissions that can be located can be tuned in by adjusting VR2 and VR3. Again, the core of L2 should only be adjusted if this should prove necessary. After having set up the oscillator for the correct frequency range, a signal is tuned in at a central setting of VR2. C1 and the core of L1 are then adjusted to peak this signal.

With the layout used, the cores of L1 and L2 cannot be adjusted by a screwdriver. However, it is a simple matter to turn the threaded brass sections by hand. The trimmers can also be adjusted by hand or by the use of any short flat object which will fit into the slot of the adjusting screw.

Detuning effects given by fitting the case lid after the tuned circuits have been set up are of a completely insignificant nature.

AERIAL AND EARTH

A suitable aerial consists of a long length of insulated aerial wire set as high above ground level as possible. It should preferably be well clear of buildings or other large obstructions. A length of about 50 feet or so should be adequate, although 100 feet or more can be used if sufficient space is available.

An earth can be provided by attaching a lead to a buried metal pipe or other metal object having a fairly large surface area. Almost any form of earth connection is very effective in increasing signal strength on the low frequency bands. Just touching the metal case of the receiver, when not earthed, will noticeably increase signal strength.

USING THE RECEIVER

This receiver is easier to operate than most simple short wave designs, but it is inevitably more difficult to use than an ordinary broadcast receiver. The oscillator of the receiver must be tuned within very close limits of the missing carrier frequency of the desired transmission, or the correct audio frequencies will not be produced.

As most transmissions on the 80 metre band use l.s.b., it is best to start with VR2 turned in an anti-clockwise direction, and then rotate the control knob in a clockwise direction in search of signals. As an s.s.b. signal is approached the pitch of the signal will be heard to fall towards the correct level, and tuning will be quite easy. Tuning in the opposite direction will also cause the pitch of the signal to fall as it is approached, but it will be unintelligible as the frequencies will be inverted and it will be necessary to tune through the signal and then make the necessary fine adjustments.

Unlike many designs, this receiver is not easily overloaded by strong signals, and strong s.s.b. signals are unlikely to suffer from distortion unless they are really exceptionally powerful or the volume control is advanced too far. The audio quality of the receiver is extremely good, so far as s.s.b. goes, and this results from the use of a high quality i.c. product detector.

The receiver offers quite a good performance, and when conditions are favourable a number of distant stations can be received. 80 metres is used mainly for comparatively short distance communication; nevertheless, using an earth and an aerial 66 feet long, the author has received stations in Canada, the U.S.A. and the West Indies.

40 METRE RECEPTION

The receiver can be converted to operate on 40 metres by fitting a modified Denco Blue Range 4T coil in the L1 valveholder and a Red Range 4T coil in the L2 valveholder. The Blue coil has an additional

RADIO & ELECTRONICS CONSTRUCTOR

AUGUST ISSUE FEATURES
12 VOLT MOTOR SPEED
CONTROLLER

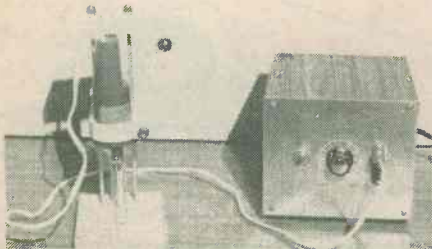

Primarily designed for use with the Precision Petite miniature electric drill, this unit may also be employed to control other small 12 volt d.c. motors drawing currents of the order of 1 amp.

★ ★ ★

3-BAND SHORT WAVE RADIO — Part 1 (2 parts)

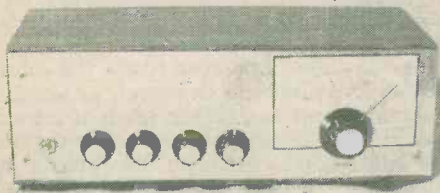

This t.r.f. design, covering 1.5 to 32MHz, requires no alignment and can be built to feed a pair of medium to high impedance headphones or, with the addition of an output stage, a 25Ω loudspeaker.

**ALL THE USUAL FEATURES
PLUS
MANY OTHER ARTICLES**

PRICE 35p

Copies may also be obtained direct from the Publishers, 46p including postage. Published by Data Publications Ltd., 57 Maida Vale, London W9 1SN.

RADIO & ELECTRONICS CONSTRUCTOR

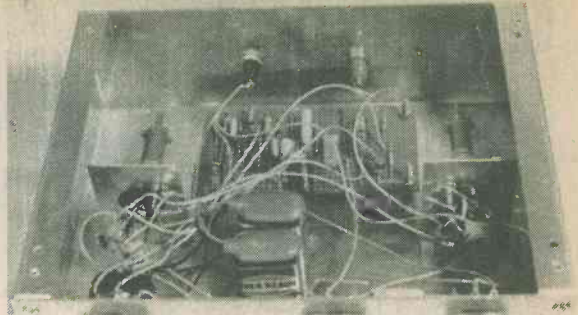

The aerial and earth sockets are mounted at the rear of the receiver, behind the component panel

47pF polystyrene capacitor and a further 10-60pF ceramic trimmer soldered across its pins 1 and 6 on the winding side of the coil former base, so that on 40 metres the aerial tuned winding is tuned by C1 (already set up for 80 metres), C2, D1 and the added 47pF capacitor and 10-60pF trimmer. The earthy end of the Range 4T oscillator coil is brought out at pin 4 instead of pin 3 but it still obtains a chassis connection, this being via C16. The core of L2 is initially adjusted such that only about $\frac{1}{8}$ in. of the metal thread is visible.

The 40 metre band is selected by adjusting the 4T oscillator coil core, and signals are then peaked up by adjusting the core of the 4T aerial coil and the added 10-60pF trimmer. In the absence of a signal generator the 40 metre band is easily located as it lies immediately on the low frequency side of the 39 metre broadcast band, with the two overlapping to some extent. This point, together with the fact that the band is only 100kHz wide, has made the band one of the less popular amongst amateurs. Nevertheless, it can still provide many interesting amateur signals.

Slightly improved results, with an increased oscillator injection voltage, will be given on the 40 metre band if the Red 4T oscillator coil is also modified. The modification consists partly of unsoldering the winding lead which connects to pin 4 and re-soldering it to pin 3. Since the earthy end of the tuned winding now connects by a short lead to chassis TR1 oscillates rather violently, and it is necessary to add a 47pF polystyrene capacitor, on the coil, across pins 1 and 3. The threaded section of the oscillator core protrudes, in this case, by about $\frac{1}{8}$ in.

Soldering to the pins of the coils has to be carried out rapidly, as the plastic material of the coil former readily melts with heat. It is advisable to plug the coil into a B9A valveholder so that the pins are held in position during soldering. The valveholder contacts will also act as small heatsinks for the pins. After soldering has been completed the coil may be removed from the valveholder when it is certain that the former material is cool and has reset to a hard condition.

(Concluded)

In your workshop

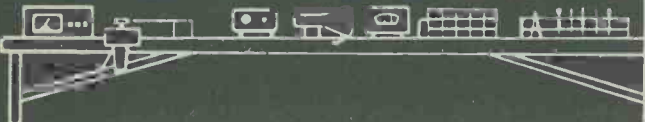

This month Smithy and Dick take a rest from their servicing duties and embark on a journey through electronics which takes them all the way from A to Z.

The butterfly fluttered fitfully outside the Workshop door, apparently uncertain about its destination or aim. At the same time, a column of ants marched purposefully in and out of a crack in the Workshop dust-bin. Dick gazed at them with a languid interest. "They're funny things," he remarked musingly.

The Serviceman opened one eye. "What are?"

"Insects," replied Dick. "Look at those ants there. They're crashing their way into and out of our dust-bin, but there's nothing in there except junk we've chucked out. Capacitors, resistors, coils, odd scraps of wire and things like that. What possible use can those be to ants?"

"Perhaps," suggested Smithy, "they're knocking up their own electronic equipment. Components are getting so tiny these days that they're probably capable of being handled by ants."

"Blimey," remarked Dick, impressed by this prospect. "It could be that they've got their ant-hill all wired up for instant communication, with worker ants taking it in turn to man the switchboard. I bet they hang around waiting for us to throw out some stuff they particularly need, and then they set off with it and connect yet another gallery into the system."

"Could be," replied Smithy, closing his eye again.

A TO Z

The butterfly had suddenly become intrigued by the circular bald patch at the top of Smithy's head, which patently offered considerable advantages as a lepidopteral air base. It hovered over Smithy's pate then, with a tremor as delicate as the twitch of an old maid's lace curtains, it settled gently on the surface. Safely alighted, it started off on a tour of inspection, following the perimeter track which was bounded on the outside by the sparse strands of hair still possessed by the Serviceman.

"Now," said Dick, returning to the mysteries of the insect world. "Take that butterfly, for instance. Butterflies disappeared for years when the DDT got them, but they're all coming back again now."

Smithy opened his eye again.

"What butterfly?"

"The one that's marching around on your bonce."

Abruptly, Smithy sat up and passed his hand over his head. Alarmed at this unexpected move, the butterfly flew away to a safer haven, from which it regarded Smithy reproachfully for some time before finally fluttering away out of sight.

"I thought I felt something there," snorted Smithy. "Dash it all, you can't even spend a lunch-hour out in the sun without some great hairy insect stamping around and leaving its mess all over you. D'you know," he added resentfully, "I was just dozing away happily then. Now, I feel all wide awake."

"Do you?" said Dick. "Well, let's do something to pass the time away."

"Such as?"

"Such as playing our A to Z game," returned Dick eagerly. "You know, the one where we go through the alphabet in turn, asking each other questions

about electronics. It's ages since we last had a go at it."

"Oh, all right," said Smithy obligingly. "Who'll start?"

"You can. With A."

"Fair enough," responded Smithy. "Well, give me admittance."

"I've just done so. You're first in the game."

Smithy sighed.

"What I mean is, tell me what admittance is. Admittance is an electrical property."

"Is it?" said Dick frowning. "Well, let me think about it. Isn't it something like conductance?"

"It's very similar," stated Smithy. "Conductance is the reciprocal of resistance, and admittance is the reciprocal of impedance. You use conductance with direct current and admittance with alternating current, and both are measured in ohms." (Fig. 1).

Admittance (MHOS) =	$\frac{1}{\text{Impedance (OHMS)}}$
Conductance (MHOS) =	$\frac{1}{\text{Resistance (OHMS)}}$

Fig. 1. The relationship between admittance and impedance, and between conductance and resistance

Dick drew breath to reply, but Smithy held up a warning finger.

"And if," he continued threateningly, "you come out with that hoary old gag about two ohms being equal to half a mho I'll personally eviscerate you."

"All right, Smithy," chuckled Dick. "I'll avoid it this time. It's my turn now with B, so what's a balun?"

"It's a transformer," stated Smithy promptly, "which matches a balanced transmission line to an unbalanced transmission line or load, or the other way round. A balanced line is one which is symmetrical about earth and an unbalanced line is one which has one side connected to earth. A very simple, although not very efficient, balun could consist of a 2:1 autotransformer coupling a 300 Ω twin feeder from an aerial to the 75 Ω unbalanced input of a receiver." (Fig. 2.)

"Don't baluns use resonant lines as well?"

"They do," confirmed Smithy. "For fixed frequency operation they can employ a matching arrangement incorporating a quarter-wave stub. But that's enough about baluns, so let's get on to letter C. What's CMOS?"

"CMOS? Why, it's that new digital i.c. business, isn't it?"

"That's right," said Smithy. "You get COSMOS as well, which is the same thing. The letters stand for 'complementary symmetry metal ox-

Your Local Supplier

LONDON

THE MODERN BOOK CO.

Largest selection of English & American radio and technical books in the country.

19-21 PRAED STREET,
LONDON, W2 1NP
Tel: 01-723 4185/2926

ST. HELEN'S RADIO

Hi-Fi Equipment
Tape Recorders
Radio Receivers
Television

SPECIALISTS IN RADIO
& ELECTRONIC TEXTBOOKS

ST. HELENS GARDENS
LONDON, W.10
Tel: 01-969 3657

HAMPSHIRE

BOURNEMOUTH

LARGEST HI-FI AND
RADIO COMPONENT
STORE IN THE SOUTH

FORRESTERS NATIONAL
RADIO SUPPLIES LTD.

70-72 Holdenhurst Road
Bournemouth

Telephone 25232

Closed all day Wednesday

SURREY

WITWORTH TRANSFORMERS

TV Line out-put transformers
Manufacturers of the largest range in
the country. All makes supplied.

Modern

BAIRD, BUSH, GEC, PHILIPS
Replacement types ex-stock.

For "By-return" service, contact
London 01-948 3702

Tidman Mail Order Ltd., Dept. R.C.
236 Sandycombe Road,
Richmond, Surrey TW9 2EQ
Callers welcome.

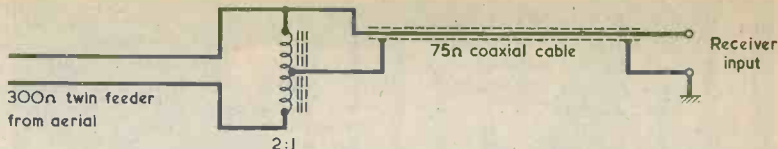

Fig. 2. A 2:1 iron-dust cored autotransformer employed as a balun. More complex arrangements are used when a higher level of coupling efficiency is required

ide silicon' and the i.c.'s use combinations of p-channel insulated gate f.e.t.'s and n-channel insulated gate f.e.t.'s. There are also CMOS op-amps as well as CMOS logic i.c.'s."

"It sounds," said Dick uneasily, "a bit complicated."

"It isn't really," Smyth assured him. "If, for example, you look at CMOS logic i.c.'s, you'll find that the simpler CMOS gates are quite easy to understand. The simplest of all is a CMOS inverter. This has a p-channel f.e.t. in series above an n-channel f.e.t., the p-channel f.e.t. connecting to a positive supply and the n-channel f.e.t. connecting to earth, or ground. The junction of the f.e.t.'s is the output. The gates are connected together, and form the input, and if they are at ground level the n-channel f.e.t. is cut off and the p-channel f.e.t. is turned on, giving a high positive voltage at the output. And if the input is high and close to the positive rail, the reverse happens and the output is low." (Fig. 3.)

DIVERSITY

"It sounds pretty easy," commented Dick, a little dubiously. "Perhaps we could have a session on CMOS at some time in the future."

"That would be an excellent idea," responded Smyth. "Anyway, it's your next, with D."

"Okay," said Dick. "What's dual diversity?"

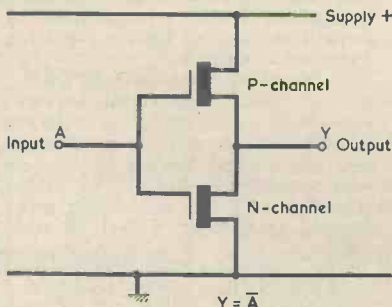

Fig. 3. The simple circuit employed in a CMOS inverter or NOT gate

"It's a form of short wave diversity radio reception which overcomes fading," replied Smyth promptly. "With dual diversity you have two receivers tuned to the same signal. They are connected to separate aerials spaced some distance apart, the idea being that the signal fades at different times on the two aerials. The two receiver outputs are coupled together, and the a.g.c. voltage of one receiver may also be used to control the gain of the other receiver and vice versa. Another approach is to have the receivers tuned to different carriers modulated with the same signal. E is next, so what's edge effect?"

"Search me," replied Dick. "I just haven't a clue."

"It's the effect you get at the edges of capacitor plates," explained Smyth. "The electrical field bulges out at the edges and causes the actual capacitance to be a little different from the capacitance calculated on plate area." (Fig. 4.)

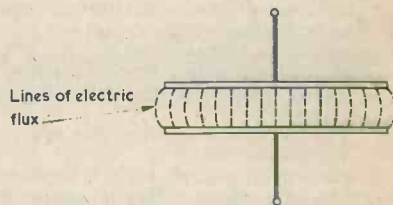

Fig. 4. Due to mutual repulsion, the lines of electric flux at the edges of two plates forming a capacitor tend to project outside the area of the plates

"All right," said Dick. "Well, let's get on to F. What are fibre optics?"

"Fibre optics?" queried Smyth. "I think that what you really mean are optical fibres. Well now, these are transparent fibres along which light flows, being reflected from side to side at the outside surface of the fibre. They can be used in ornamental light arrays, but they have a number of serious applications as well. There's a lot of development work going on at the time being on the possibility of using optical fibres as transmission lines

Your Local Supplier

LONDON

THE MODERN BOOK CO.

Largest selection of English & American radio and technical books in the country.

19-21 PRAED STREET,
LONDON, W2 1NP
Tel: 01-723 4185/2926

ST. HELEN'S RADIO

Hi-Fi Equipment
Tape Recorders
Radio Receivers
Television
SPECIALISTS IN RADIO
& ELECTRONIC TEXTBOOKS

ST. HELENS GARDENS
LONDON, W.10
Tel: 01-969 3657

HAMPSHIRE

BOURNEMOUTH

LARGEST HI-FI AND
RADIO COMPONENT
STORE IN THE SOUTH

FORRESTERS NATIONAL
RADIO SUPPLIES LTD.
70-72 Holdenhurst Road
Bournemouth
Telephone 25232
Closed all day Wednesday

SURREY

WITWORTH TRANSFORMERS

TV Line out-put transformers
Manufacturers of the largest range in
the country. All makes supplied.

Modern
BAIRD, BUSH, GEC, PHILIPS
Replacement types ex-stock.
For "By-return" service, contact
London 01-948 3702

Tidman Mail Order Ltd., Dept. R.C.
236 Sandycroft Road,
Richmond, Surrey TW9 2EQ
Callers welcome.

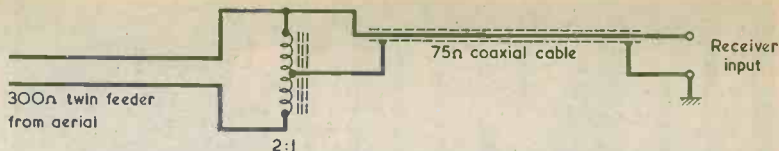

Fig. 2. A 2:1 iron-dust cored autotransformer employed as a balun. More complex arrangements are used when a higher level of coupling efficiency is required

ide silicon' and the i.c.'s use combinations of p-channel insulated gate f.e.t.'s and n-channel insulated gate f.e.t.'s. There are also CMOS op-amps as well as CMOS logic i.c.'s."

"It sounds," said Dick uneasily, "a bit complicated."

"It isn't really," Smithy assured him. "If, for example, you look at CMOS logic i.c.'s, you'll find that the simpler CMOS gates are quite easy to understand. The simplest of all is a CMOS inverter. This has a p-channel f.e.t. in series above an n-channel f.e.t., the p-channel f.e.t. connecting to a positive supply and the n-channel f.e.t. connecting to earth, or ground. The junction of the f.e.t.'s is the output. The gates are connected together, and form the input, and if they are at ground level the n-channel f.e.t. is cut off and the p-channel f.e.t. is turned on, giving a high positive voltage at the output. And if the input is high and close to the positive rail, the reverse happens and the output is low." (Fig. 3.)

DIVERSITY

"It sounds pretty easy," commented Dick, a little dubiously. "Perhaps we could have a session on CMOS at some time in the future."

"That would be an excellent idea," responded Smithy. "Anyway, it's you next, with D."

"Okay," said Dick. "What's dual diversity?"

"It's a form of short wave diversity radio reception which overcomes fading," replied Smithy promptly. "With dual diversity you have two receivers tuned to the same signal. They are connected to separate aerials spaced some distance apart, the idea being that the signal fades at different times on the two aerials. The two receiver outputs are coupled together, and the a.g.c. voltage of one receiver may also be used to control the gain of the other receiver and vice versa. Another approach is to have the receivers tuned to different carriers modulated with the same signal. E is next, so what's edge effect?"

"Search me," replied Dick. "I just haven't a clue."

"It's the effect you get at the edges of capacitor plates," explained Smithy. "The electrical field bulges out at the edges and causes the actual capacitance to be a little different from the capacitance calculated on plate area." (Fig. 4.)

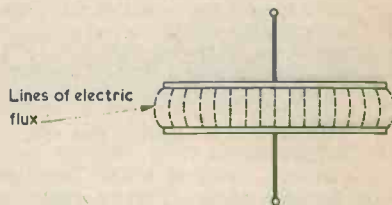

Fig. 4. Due to mutual repulsion, the lines of electric flux at the edges of two plates forming a capacitor tend to project outside the area of the plates

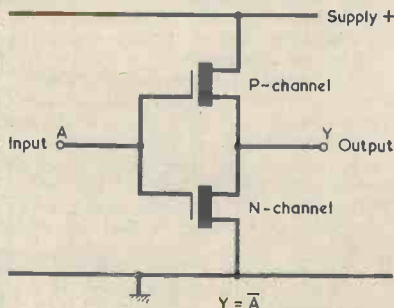

Fig. 3. The simple circuit employed in a CMOS inverter or NOT gate

"All right," said Dick. "Well, let's get on to F. What are fibre optics?"

"Fibre optics?" queried Smithy. "I think that what you really mean are optical fibres. Well now, these are transparent fibres along which light flows, being reflected from side to side at the outside surface of the fibre. They can be used in ornamental light arrays, but they have a number of serious applications as well. There's a lot of development work going on at the time being on the possibility of using optical fibres as transmission lines

for long distance telephone circuits instead of coaxial cable. You can send modulated light signals quite a long way via an optical fibre, with about 5 kilometres between repeaters."

"Repeaters?"

"Amplifiers," explained Smithy, "to boost the signal."

"How is the signal fed into the optical fibre?"

"By means of a modulated laser or a modulated light-emitting diode. The laser allows higher modulating frequencies. Well, it's my turn now with G, so tell me what Gray code is."

"Hey, Smithy," protested Dick. "You aren't half giving me some tough ones today. I haven't the vaguest idea what Gray code is!"

"It's a binary code used for servo control systems," explained Smithy. "A snag with ordinary binary for these applications is that there's an abrupt change when you go from, say, binary 111 to the next number, which is binary 1000. This change is abrupt because three 1's change to three 0's. With the Gray code only one digit changes as you proceed from one number to the next, and this makes it easier for the control systems to operate reliably." (Fig. 5.)

"I'll take your word for it," grinned Dick. "Now you tell me what harmonics are."

"That's an easy one," replied Smithy. "A harmonic of a frequency is a multiple of that frequency. Thus, the second harmonic of 1kHz is 2kHz, the third harmonic is 3kHz and so on."

DECIMAL	BINARY	GRAY CODE
0	0000	0000
1	0001	0001
2	0010	0011
3	0011	0010
4	0100	0110
5	0101	0111
6	0110	0101
7	0111	0100
8	1000	1100
9	1001	1101
10	1010	1111
11	1011	1110
12	1100	1010
13	1101	1011
14	1110	1001
15	1111	1000

Fig. 5. Binary and Gray code equivalents of decimal zero to 15. The binary and Gray code numbers are in four-digit groups. Note that there is only a change of 1 bit when Gray 15 changes to Gray zero, allowing the Gray code to be employed in a circular sensing system having 16 equal segments

"In other words," said Dick, "they're the same as overtones."

"They aren't, you know," retorted Smithy. "Lots of people get muddled between harmonics and overtones. If you have a complex alternating signal the overtones are the frequencies in the signal that are higher than the basic frequency of the signal. Unlike harmonics, they don't have to be exact multiples of the basic frequency."

"I didn't know that before."

"Well, you do now," said Smithy. "You're complaining that I've been giving you hard ones so I'll give you a nice easy one next. What's an integrating circuit?"

"That's too easy," scoffed Dick. "It's a device with a lot of transistors, diodes and resistors diffused on a silicon chip."

"I didn't say integrated circuit, you twit," snorted Smithy. "I said integrating circuit."

"Oh, that! It's still an easy one. You get an integrating circuit when you have a series resistor going into a parallel capacitor." (Fig. 6.)

"Very good," said Smithy. "And you find integrating circuits in television sync circuits, where they sort out the broad vertical sync pulses from the short horizontal sync pulses."

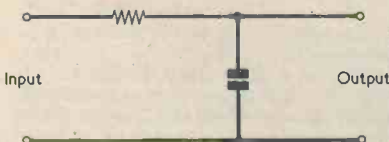

Fig. 6. An integrating circuit. The voltage across the capacitor varies slowly in response to quick voltage changes at the input

JUGFET

"It's J now," said Dick. "So it's me to give you one. What a JUGFET?"

"That's a junction gate f.e.t. Okay, what's keystone distortion?"

"Is this something to do with television?"

"It is."

"Let me think now," mused Dick. "Ah, I know. It's the effect given in a television system when the action's going too fast!"

"It's what?"

"Keystone distortion," repeated Dick, "is given when there's too fast an action."

"How in heaven's name," queried Smithy bemusedly, "do you arrive at that?"

"Well," stated Dick defensively, "it's distortion like you get with those old films of the Keystone Cops! They're rushing around faster than normal and bashing their cars into each other; and it's all happening quicker than real life."

Your Local Supplier

SUSSEX

JEFFRIES

For
Hi-Fi Equipment
Tape Recorders
Television
Transistor Radios

6A Albert Parade
Victoria Drive,
EASTBOURNE SUSSEX

EIRE

PEATS for PARTS ELECTRONIC COMPONENTS RADIO & TELEVISION

For the convenience of Irish
enthusiasts we supply
Radio & Electronics
Constructor
Data Books and
Panel Signs Transfers
Also a postal service

Wm. B. PEAT & Co. Ltd.
28 PARNELL STREET
DUBLIN 1

MORSE MADE EASY

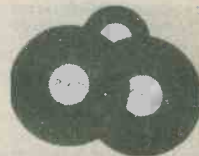

BY THE RHYTHM METHOD!

If you start RIGHT you will be reading a amateur and commercial Morse within a month. (normal progress to be expected.)

Using scientifically prepared 3-speed records you automatically learn to recognise the code RHYTHM without translating. You can't help it. It's as easy as learning a tune. 18-W.P.M. in 4 weeks guaranteed.

The Complete Course consists of three records as well as two instruction books, a Beginner's 12 in. L.P., an Advanced Student's 12 in. L.P. and a 7 in. E.P., all of which are played at three speeds.

For Complete Course send £4.95 including P.P.I. etc. (overseas surface mail £1 extra).

THE MORSE CENTRE

Box 8, 45 Green Lane, Purley, Surrey.

I enclose £4.95 or large s.a.e. for explanatory booklet.

Name

Address

The Serviceman cast his eyes up to the blue skies above.

"I must," he said, "have heard everything now. Keystone distortion, you great nit, is given when a deflection yoke fault causes a television picture to be shorter at one edge than it is at the opposite edge." (Fig. 7.)

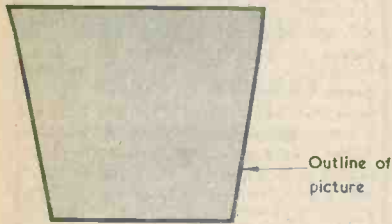

Fig. 7. Keystone distortion is given when one edge of a television picture is shorter than the opposite edge. Here, the bottom edge is the shorter one, but keystone distortion applies also to the cases where either side or the top is shorter

"Then why do they call it keystone distortion?"

"Because that's the shape of the keystone at the top of an arch. You're next, with L."

"All right," returned Dick in a nettled tone. "What's a local oscillator?"

"It's a chap who keeps going in and out of his pub at a regular frequency."

Dick looked blank.

"That," grated Smyth, "was intended to be a joke."

"Was it? Oh I see, you're referring to a pub as a 'local'. Why, it's very good. Ha-ha!"

The glance Smyth bestowed on his assistant was reminiscent of Medusa in one of her more inspired moments.

"A local oscillator," he ground out, "is a rather old-fashioned name for the oscillator in a superhet. Well, if you're going in for old-fashioned terms, here's a really ancient one. Motor-boating."

"Ah, I know that one," stated Dick proudly. "It's a.f. instability in an amplifier which results in a sort of put-put noise, rather like the sound of a motor-boat."

"Good," said Smyth, mollified. "But I wouldn't say it was necessarily a.f. instability. You could well have some supersonic feedback causing the effect, rather in the nature of a squeegging oscillator. Whose turn is it next?"

"Mine," declared Dick, "with N. What's a node?"

"It's the opposite of an antinode."

"So?"

"Well," said Smyth. "If you have a standing wave on a length of wire, there will be points along the wire where the current change is at its highest level and points where the

current change is at zero level. The points of maximum change are current antinodes and those of zero change are current nodes. You can use the words 'antinode' and 'node' to describe the points of maximum and minimum effect in other resonant systems, such as can appear in a violin string and so on. Okay, I'll come back to you now and ask you what Ohmic resistance is."

"Ohmic resistance?" repeated Dick. "Blimey, I thought *all* resistance was Ohmic."

"It's a term you encounter in integrated circuits mainly," explained Smyth. "The internal connection from the i.c. pin to the particular piece of doped silicon it passes to is referred to as having Ohmic resistance because it follows Ohm's Law. This differentiates it from the doped silicon, which may be non-linear so far as its resistance is concerned."

"How do you mean, non-linear?"

"The voltage it drops is not proportional to the current passing through it," explained Smyth. "And so it doesn't follow Ohm's Law."

"I get it," said Dick. "P's next, so how about P.M.?"

"P.M.?"

"P.M." repeated Dick firmly.

"You wouldn't," stated Smyth suspiciously, "be taking the Michael, would you?"

"Not at all," returned Dick. "P.M. is a perfectly acceptable abbreviation."

"It obviously stands for Prime Minister, but that's nothing to do with electronics. Oh, I know. Post Meridian!"

"Hey?"

"Post meridian," pronounced Smyth. "That's what P.M. stands for when you're talking about times between noon and midnight."

"It's not that."

Smyth thought.

"Post mortem," he offered. "Like the post mortems engineers hold when they've successfully run a difficult fault down to earth."

"That's not it, either."

Smyth concentrated.

"Prostate massage?"

"Nope."

"Then I give up. What is it?"

"Phase modulation," cried Dick triumphantly. "A.M. is amplitude modulation, F.M. is frequency modulation, and P.M. is phase modulation."

Q FACTOR

"Well," said Smyth ruefully, "you certainly caught me there. My turn now, and so I'll give you Q."

Dick waited expectantly.

"That's it," growled Smyth. "The one I'm giving you for Q is Q!"

"Oh, I see," responded Dick.

"That's quite easy then. The letter Q refers to the efficiency of a tuned circuit. If it's a tuned circuit with very few losses we say that it has a high Q."

"That's fair enough," conceded

Smyth. "In a tuned circuit, Q defines the voltage magnification given at resonance and is approximately equal to the reactance of the coil divided by its resistance. You'll find the letter Q used to define the quality factors of other things as well, such as capacitors and insulating materials. It's also used in quite a different context as standing for a quantity of electricity or the number of coulombs which is held, say, by a charged capacitor. However, you don't encounter this second meaning in normal working electronics."

"Okeydoke," said Dick equably.

"I've got a really good one for R."

"Fire away."

"What," asked Dick cheerfully,

"does 'radiesthesia' mean?"

"Radiesthesia?"

"That's right. Radiesthesia."

"I've never heard of it."

"Radiesthesia," stated Dick, "is the scientific name for dowsing, or water divining."

"Do you mean that business where blokes discover water by walking over the ground with bent sticks in their hands?"

"I do," confirmed Dick gleefully. He chuckled. "I've been saving this one up for ages."

"But what the heck," exploded Smyth, "has water-divining got to do with electronics?"

"Nobody knows how water divining works," retorted Dick, "so who can say that it *doesn't* have something to do with electronics?"

"Humph," grunted Smyth irritably. "I reckon that's an unfair one. Well, it's me to go next, so you tell me what a swinging choke is."

Dick shuddered.

"Gosh, that sounds horrible," he remarked. "It brings to my mind a picture of a geyser gyrating on a gibbet."

"You've been seeing too many late night horror films," commented Smyth. "In practice, you'll find a swinging choke in a mains power supply having a choke input and no reservoir capacitor. Judging by the baffled look on your face, it seems that I'll have to give you a bit of background first."

"I think you'll have to."

"Well," said Smyth. "A power supply with a choke input is the sort of thing you find in amateur transmitters, and it's intended to offer a high voltage which doesn't vary too much despite widely varying current demands. It could, for instance, have a centre-tapped mains transformer secondary connected to a full-wave rectifier." (Fig. 8(a).)

"Doesn't a choke input circuit automatically give you a steady voltage at different load currents?"

"Not entirely," responded Smyth.

"When sufficient current is drawn from a full-wave rectifier supply with choke input the output voltage stabilizes at approximately 0.9 times the r.m.s. value of the voltage applied to each rectifier anode by the mains transformer. However, if no current is

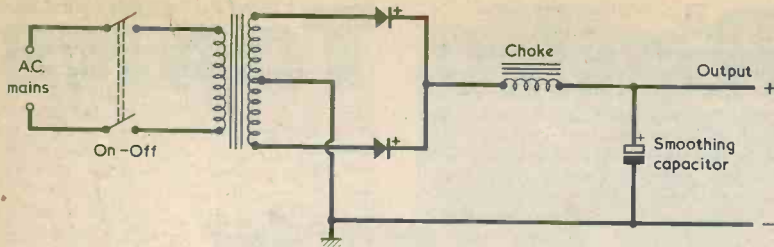

(a)

Fig. 8(a). A full-wave rectifier circuit with choke in input

(b). A swinging choke is frequently employed in power supplies where current demand varies widely. Apart from discharging the smoothing capacitor after switch-off, the bleeder resistor also ensures that a minimum current is always drawn

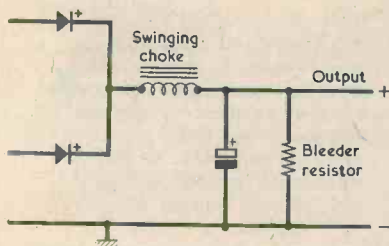

(b)

drawn the voltage across the smoothing capacitor following the choke rises to the peak value of the alternating voltage applied to each rectifier anode."

"But," interjected Dick, "the choke should stop that, shouldn't it?"

"The function of the choke," replied Smithy, "is to oppose changes of current. But if there is no load current at all the choke simply allows the smoothing capacitor to charge up to peak voltage. So, a choke input circuit can only give good regulation if a load current is drawn from the supply. It isn't difficult to visualise the fact that the smaller the load current the greater is the inductance needed in the choke to prevent the smoothing capacitor charging to a potential higher than 0.9 times the r.m.s. value. Put another way, the choke inductance required for good voltage regulation decreases as load current goes up. And this is where the swinging choke comes in. A swinging choke is a choke whose effective inductance decreases as the current flowing through it increases. We first of all make certain that some load current is always drawn by connecting a bleeder resistor across the smoothing capacitor. This also ensures that the capacitor is quickly discharged when the supply is switched off, and prevents unpleasant shocks. We then put a swinging choke in circuit. This has sufficiently high inductance at the low minimum current to provide the required regulation. As load current increases, the choke inductance goes down, but this doesn't matter because a lower inductance is all that's needed then." (Fig. 8(b).)

"This seems very complicated," remarked Dick critically. "Why go to all the trouble of having a swinging choke when you could use a choke which more or less holds its inductance value at all currents?"

"Because the swinging choke is cheaper," explained Smithy. "It can have a smaller iron core and a lighter construction than a choke which offered an unnecessarily high inductance at all currents."

TOGGLE

"Stap me," exclaimed Dick, struck by this revelation. "It makes sense when you look at it like that. Well, that's got S and swinging choke out of the way, so it's me now with T. What's a toggle?"

"It's a term sometimes used to describe a flip-flop. What's unilateralisation?"

"Wait a minute," said Dick, frowning. "That word seems to ring a bell. Isn't it some form of neutralisation?"

"It is," confirmed Smithy. "It was the form of neutralisation that was used with germanium i.f. transistors in the earlier transistor radios. To give complete neutralisation, a resistor was inserted in series with the neutralising capacitor."

"I'm next," said Dick quickly, "with V. What's a varactor?"

"It's a silicon diode whose capacitance varies according to the reverse voltage applied across it. The same sort of thing as occurs with a varicap diode. Now, how about wow?"

GAREX

Modulation transformers
Valve type 747, for 30W Tx £2.80
Transistor type, p/p NKT404 to QV03-20a (or QV03-10), with driver transformer to match - special offer - the two £1.30
Mains transformer (multitap primary) 250-0-250V 200mA, 6.3V 5A, 5V 2A, fully shrouded, (suitable for 30W Tx - matching style to mod. transf.) £5.95
Connection data supplied with transformers.
H.T. chokes 5H 80mA, 1.8H 125mA £1.25
Relays GPO type 2400, 12V coil, 8A contacts, 4PCO or 2P make 40p each; 5+: 25p
Neons min. wire end, 55p/10; £4/100
Slide Switches min. DPDT 15p ea; 5+: 12p
2 pole, 3 position 22p each; 5+: 18p
PL259 UHF Plug & Reducer 60p; 5+: 50p
SO239 UHF Socket panel mtd. 45p; 5+: 36p
BNC cable mtg Socket 50Ω 15p; 5+: 12p
Resistor Kits 10E12 5% C-Film, 10 each value 22Ω to 1M (570 pcs) ½ or ¼W £4.75
Numericators ZM1080 75p each; 5+: 63p
I.C.'s (new, full spec.) CD4001AE 40p
SN76660 FM Quad. detector £1.12
723 Voltage reg. TO5 metal case 90p
NE555 Timer 75p
709 (TO5); 741 (DIL-8) Op. amps 25p each
5+ I.C.'s (any mix) at 20% discount
Nicaid rechargeable cells HP7 size £1 each.
4+: 90p. 10+: 85p. new, recent manufacture.

Prices include UK Post. Packing & VAT

Mail-order only Sole Address:

GAREX ELECTRONICS

7 NORVIC ROAD, MARSWORTH,
TRING, HERTS HP23 4LS
Cheddington (STD 0296) 688684

555 Timer 38p; Slide Switches DPDT 10p; Log. Pots 5, 10, 25, 250, 500K, 1M 17p; Lin Pots 500K 17p; Switched Log & Lin 31p; Stethoscope Earphone 8 ohm 3.5mm plug £1.12; Resistors — ¼W 5% E12 1 ohm to 2.2 Meg 1p, ½W 10% E12 2.7 Meg to 10 Meg 1p; Volex Mains Plug 38p; LM3909 LED Flasher 68p; Alligator Clips 11p/pair; Multicore Solder 9p/metre; Miniature Transformers, LT 44 25p, LT 700 28p; Speakers 70mm 80 ohm 95p, 70mm, 56mm, 50mm, all 8 ohm 55p; Printed Circuit Kit £2.65; IN4148 3p; 5 pin din 18p; 5 pin din socket 10p; 3 pin din plug 13p; 3 pin din socket 10p; 2 pin din L/S plug 9p; Solder tags 10 for 5p; Push on-release off switches 14p; BC107/8/9 9p; Denco D.P. Coils, ranges 1 to 5 green 78p; blue, yellow, red, white 74p; Ranges 6 to 7 B.Y.R. 64p; Mains Cable 10p/metre. Coax 75 ohms 10p/metre; Coax 50 ohms/metre; Aerial wire 75 metres £2.90; Digital Clock Kits — Modules by National Semiconductors ¼" LED display: Clock, 12 or 24 hour £14.37; Clock, Alarm, 12 or 24 hour £15.37.

MAIL ORDER ONLY PRICES INCLUDE TAX

Add only 20p for post and packing.
Send 15p for catalogue and lists.

CLEVELAND SUPPLIES (REC)

P.O. Box 20, Redcar, Cleveland

Radio Topics

By Recorder



"How about it, indeed! That's a hi-fi term, Smithy. Wow is given when you get a slow cyclic change of pitch with reproduced music because the tape isn't going through, or because the record turntable isn't revolving, at a constant speed."

"You've got it," commended Smithy. "Incidentally, it is also the cause of much agony amongst people in pubs or restaurants where there is canned background music with wow on it. The people who run these places just don't notice the wow and they seem to think they're actually doing the customers a favour by laying on the music. I feel sometimes I could kick them in the cassette."

"Wow," remarked Dick, "always seems to show up worst with recordings of piano music."

"Piano music," agreed Smithy, "is an excellent medium for detecting wow. A piano tone continues after the key has been struck, and there is no vibrato or tremolo to mask the wow."

He glanced at his watch.

"We'd better wind it up," he said briskly. "Your turn next, with X."

"Trust me to get the rotten letters at the end," complained Dick. "All right, I'll do the same as you did with Q. What's X?"

"It's the symbol for reactance," stated Smithy. "Now, what's a Y-network?"

"Is it the network which handles the monochrome part of a colour TV signal?"

"The answer is easier than that."

"Now, let me see," said Dick thoughtfully. "Why of course, it's dead simple! You have T-networks and pi-networks, so you can also have Y-networks. It's a network which can be drawn in circuit form in the shape of a letter Y."

Smithy nodded an assent.

"Good show," said Dick cheerfully. "I'll give you Z now. Zoom lens."

"A zoom lens," stated Smithy, "is a lens system which enables a television or film camera to have a considerable and continuously variable distance range without losing focus."

WORK RESUMED

"That's it," said Dick. "And that's the end of another little run through the alphabet."

"A pleasant way of passing the time, too," said Smithy. "Oh well, I suppose we'd better get back inside again."

Whereupon the two wandered back inside the Workshop carrying their stools with them. The Workshop door closed.

Shortly afterwards, there was a flutter of colour and the butterfly reappeared. It hovered over the area previously occupied by Smithy, prompted presumably by a fleeting memory of the Serviceman's scalp which it had investigated so closely earlier. Then, aimlessly, it drifted away, weaving a radiant hap-hazard pattern in the gentle July air. ■

It may come as a surprise to some U.K. readers to learn that a controversy about the transistor versus the valve has been simmering away amongst American audiophiles ever since solid-state hi-fi amplifiers appeared on the scene many years ago. The purists claim that, despite the fact that transistor amplifiers successfully pass laboratory distortion tests, they still offer a different 'sound' to that given by valve amplifiers.

It seems that even if all the obvious causes of distortion, such as clipping and poor crossover performance in the output stage, are cleared up, there is still something wrong with transistor amplifiers. One theory is that transistors create higher order harmonics than do valves and that, given comparable total harmonic distortion figures, these are more disturbing to listeners.

HIGH POWER F.E.T.

The last thing I want to be drawn into is an argument about the relative performance of valves and transistors, and I have mainly mentioned the dispute because it affords an effective introduction to a new semiconductor device which is reported in the December 1975 issue of our American contemporary *Radio-Electronics*. In this issue an article, 'Power FET For Audio' by Len Feldman, describes the development of a new high power f.e.t. by Professor Nishizawa of Tohoku University in Japan. This f.e.t. can be employed in the output stage of an amplifier, whereupon it gives a performance approaching that given by a triode valve, as opposed to that given by a bipolar transistor.

We normally look upon the f.e.t. as a device which passes currents in the order of milliamps. Current from the source to the drain flows along the channel between these two electrodes, its amplitude being regulated by the

voltage on the gate. The channel is quite thin and, in consequence, the device is capable of passing only a low current.

The f.e.t. produced by Professor Nishizawa has a very much larger channel. The source is on one surface of the chip and the drain is on the opposite surface, whereupon virtually the whole volume of material between them constitutes the channel. The gate appears, with a grid-like formation, inside the channel just below the source. The current which passes through the interstices of the gate is then the source-to-drain current, and its amplitude can be controlled by the potential on the gate. As you can see, there is a striking similarity with the triode valve.

This new method of f.e.t. construction allows two f.e.t.'s to appear in a totem-pole push-pull output stage, and an all-f.e.t. stereo amplifier employing such as an output stage has been marketed by Yamaha. This is stated to offer an output of at least 150 watts per channel of continuous power at any frequency from 20Hz to 20kHz with no more than 0.1% of total harmonic distortion. The output f.e.t.'s are type YT-304 and an idea of the current they handle can be gleaned from the fact that the amplifier channels can work into 8Ω or 4Ω loads.

It has sometimes been said that if the f.e.t. had been invented before the bipolar transistor much of our present-day linear semiconductor designs would be f.e.t. based, simply because the development work which has been carried out on the bipolar transistor would have been directed to the f.e.t. instead. The truth of that supposition will never now be discovered, but it could well be that the voltage controlled f.e.t. will now become a really serious rival to the current controlled bipolar transistor in the hi-fi amplifier designs of the future.

QUARTZ CRYSTALS

My two photographs this month also reflect the U.S. scene, although the processes illustrated are applicable anywhere where piezoelectric quartz crystal wafers are produced. The photographs come from Varian Lexington Vacuum Division, 121 Hartwell Avenue, Lexington, Mass., U.S.A., and depict steps in the production of quartz crystals at the plant of Tyco Crystals Products, a division of Tyco Laboratories, Inc. of Boston. The point of the accompanying story is that production has greatly increased, direct labour and wastage has been reduced, and an improved quality product obtained by the introduction of Varian Model 686 Wafering Machines, which are capable of accurately and efficiently slicing virtually any material to close tolerance dimensions.

The frequency at which a quartz wafer oscillates is largely a function of its thickness. Also, the quartz wafer has to be cut from the parent crystal at a particular and precise angle to the crystal axes to obtain the desired activity and temperature-frequency characteristic. Both of these requirements involve fabrication to very close limits on dimensions and angle of cut. In the case of the latter, tolerances of the order of plus or minus one minute of a degree are quoted.

At Tyco Crystals Products, the production of crystal slices proceeds in the following manner. The raw material, a quartz bar approximately 6 by 0.8 by 0.41 in. is first trimmed at the ends to a 35 degree angle. Next, the bar is cut down the centre with a rotary diamond saw, removing the long crystal seed.

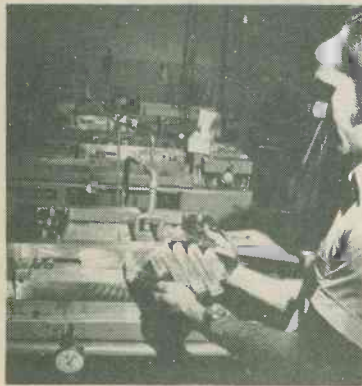

Holding a plate with piezoelectric quartz bars, an operator at Tyco Corporation's Crystal Products Division is about to cut these into fine wafers using a Varian Model 686 Wafering Machine. The machine produces about 1,000 wafers in 4 hours



Here, the Wafering Machine is in process of cutting the quartz bars. A slurry consisting of silicon carbide abrasive suspended in viscous oil is fed in via the pipe at the top of the machine, and the actual cutting is carried out by the abrasive particles

A double diffraction X-ray apparatus is then used to set the precise crystal bar orientation on a transfer fixture. Four bars are bonded to the metal transfer fixture at the correct orientation, and the loaded fixture is mounted on the Varian wafering machine. The cutting action then begins.

Highly tensioned smooth-edged steel blades 0.008 in. thick reciprocate at 100 strokes per minute in a horizontal plane across the top of the quartz bar. A liquid slurry consisting of a specially treated viscous oil and silicon carbide abrasive is applied. The abrasive in the oil flows under and on each side of the blade, wearing away material and forming a groove equal to the thickness of the blade, plus some characteristic side wear depending upon the size of the abrasive particles. Generally, the width of the groove is 0.013 to 0.015 in.

At the same time, a pre-set, carefully controlled, vertical pressure is applied to the material from below so that the work rises through the cutting blades as the material is removed. The cutting process takes about 4 hours, producing about 1,000 wafers, 0.017 in. thick by 0.41 in. square, per machine. The wafers are then cleaned by dipping and shaking, and samples are X-rayed to verify the original critical bar set-up angle. After this, the wafers are waxed together into 1 in. long bars and run through a lathe to round them. The wax is removed and they are lapped down to a thickness of 0.010 in. Finally, the crystal unit department plate-mounts, frequency-adjusts, and encapsulates the crystal slices for their ultimate frequency controlling application.

It is stated that the new Varian machines produce a 95% yield, and also enable the current very high de-

mand for frequency control crystals to be satisfied. This demand stems largely from the increasing quantities of Citizen's Band two-way radios and electronic watches which are now being manufactured in the United States.

SOLDER AGAIN

The production of good solder joints is so essential for the successful construction of electronic projects that I hope you will excuse me if I bring up the subject of solder yet again.

Both my friends and myself have noticed what appears to be an increasing shortage of good quality radio-type solder at the counters of do-it-yourself shops, ironmongers and similar retailers in provincial towns. Instead, what appears to be offered more and more are resin cored solders which admit to being 40% of tin to 60% of lead, or somewhat dubious types of solder which merely state that they are of 'electrical quality' or are 'for electrical joints'. These 'electrical' solders are almost certain to consist of 40/60 alloy.

The only solders which should be employed for electronic work are either resin cored 60/40 alloys (i.e. 60% of tin and 40% of lead) or the special 'Savbit' alloy which is produced by Multicore. 'Savbit' is nearly the same as 60/40 but it has a little added copper to prevent migration of copper from the soldering iron bit.

Now, tin is more expensive than lead and so 40/60 alloy is cheaper than 60/40 alloy. Also, 40/60 alloy is a perfectly good solder for electrical joints which are made with a large soldering iron. But for small close electronic work with a miniature iron, such as is given in the soldering of the pins of an integrated circuit, 40/60 alloy is a dead loss.

On cooling, 60/40 solder changes from the liquid to a 'pasty' condition at 188°C, and then sets solid at 183°C. The 40/60 alloy, on the other hand, changes from liquid to 'pasty' at the much higher temperature of 234°C, after which it sets solid at the same temperature, 183°C, as 60/40 solder. The wide temperature range over which 40/60 alloy is in the 'pasty' condition is what makes it unsatisfactory for close electronic work. If you try it, you'll probably find that it appears quite reasonable for the first dozen joints or so, but after this you'll notice an accumulation of cloggy 'pasty' solder on the soldering iron tip which has to be continually cleaned off. Also, subsequent joints become less and less successful due to build-up of 40/60 alloy on the iron tip.

So, for successful electronic soldering always insist on resin cored 60/40 alloy or 'Savbit'. If you can't get a good solder from local shops the only thing to do is to purchase it from one of the mail-order component houses. Nearly all of these sell solder of the correct quality for electronic use. ■

VOLTAGE CALIBRATOR FOR OSCILLOSCOPES

By C. F. Edwards

A low cost design which produces a signal having a peak-to-peak amplitude of 1 volt.

Articles describing circuits for oscilloscope voltage calibration appear from time to time, and in general these consist of designs which produce a square wave of known amplitude. The circuits are fairly complex and require at least a square wave generator as well as a means of controlling the peak-to-peak voltage of the waveform produced.

This article describes a very simple approach towards obtaining a waveform of known amplitude, and it requires nothing more than a small mains transformer, two silicon rectifiers and three resistors. A small price has to be paid for simplification at this level, and the shortcomings (if they merit this description) of the present circuit are that the waveform it provides is not a true square wave and that its frequency is at the rather low value of 50Hz. Neither of these factors represents any serious disadvantage if the oscilloscope being calibrated has a wide frequency response. On the credit side is the fact that the waveform produced has a very accurate and measurable constant level of 1 volt peak-to-peak.

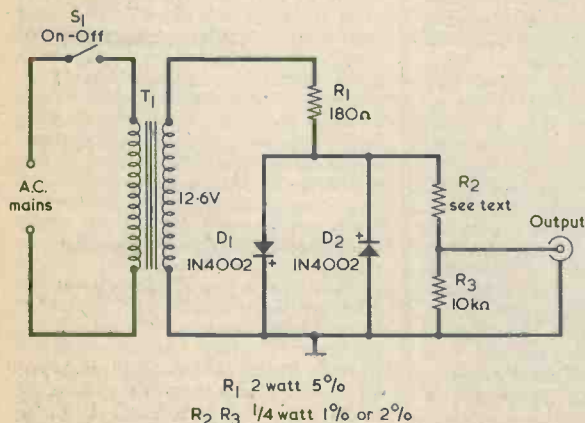

Fig. 1. The circuit of the voltage calibrator

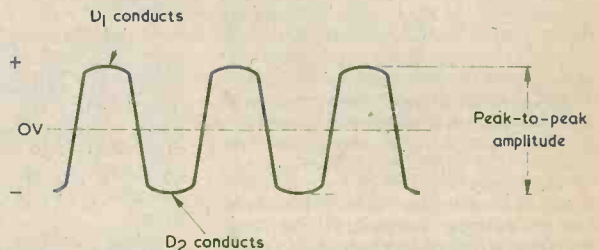

Fig. 2. The waveform produced by the calibrator is not a perfect square wave. Discrepancies are shown here in exaggerated form

SILICON RECTIFIERS

The circuit of the unit appears in Fig.1. Here, the 12.6 volt secondary of a mains transformer is coupled via R1 to two silicon rectifiers connected back to back. During half-cycles when the upper end of the secondary is positive, rectifier D1 conducts and a voltage of about 0.7 to 0.9 volt appears across it. During the alternate half-cycles diode D2 conducts and, again, a voltage of about 0.7 to 0.9 volt is given across this diode. Thus, a waveform of about 1.4 to 1.8 volts peak-to-peak is passed to R2. This resistor has a value which ensures that the waveform across R3 is precisely 1 volt peak-to-peak, and this is the waveform which is applied to the oscilloscope to be calibrated.

The waveform produced across R1 and D2 is not a perfect square wave. The transition from positive to negative and from negative to positive is not instantaneous but takes a small finite time. Also, the forward voltage dropped across each diode is not constant but increases slightly with increase in forward current. These two effects are illustrated in exaggerated form in Fig.2. The peak-to-peak voltage is, of course, that between the most positive and negative points, and this voltage may be readily set up under static conditions.

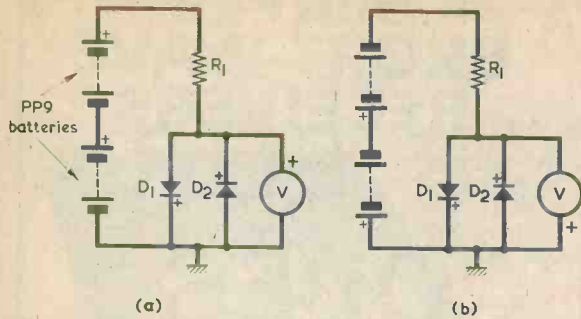

Fig. 3(a). Finding the peak forward voltage developed across D1
 (b). The battery and voltmeter polarities are reversed to find D2 peak voltage

FORWARD VOLTAGE

The highest positive and negative amplitudes of the waveform are produced when the transformer secondary voltage is at its peak value. The r.m.s. value of the secondary voltage is 12.6 volts, whereupon the peak voltage is 1.414 times this value, or 17.8 volts.

The first task before completing the wiring of the calibrator consists of finding the forward voltage across D1 when a positive voltage of 17.8 volts is applied to R1, and this can be achieved with the test circuit shown in Fig.3(a), in which the voltmeter is a testmeter switched to a low volts range. The 17.8 volts is provided here by two PP9 batteries in series. If these are new and unused batteries they will give, at the current flowing through R1 and D1, a voltage which is more than adequately close to 17.8 volts for the present purpose. If a variable voltage power supply is available, this can be set accurately to 17.8 volts and employed instead of the batteries. The current drawn via R1 and D1 is of the order of 100mA, and so it is necessary to use fairly large batteries, such as the PP9, or a power supply capable of producing this current. The voltage dropped across D1 is measured by the voltmeter and is noted. When batteries are used, they should be connected just long enough to enable the voltage reading to be taken, as they will otherwise be unnecessarily exhausted by the high current.

The process is then repeated for D2 with the negative output from the batteries of the power supply connecting to R1 and with the voltmeter polarity reversed, as in Fig.3(b). The forward voltage dropped across D2 is also noted.

PEAK-TO-PEAK VALUE

The sum of the two forward voltages then represents the peak-to-peak value of the waveform that will be applied to R2. Let us take an easily calculated example, and say that the forward voltage across D1 is found to be 0.8 volt and that across D2 0.7 volt. The peak-to-peak amplitude of the waveform applied to R2 is thus 1.5 volts; whereupon the voltage across R3 will be 1 volt if R2 is given a value of 5kΩ. It is likely that the figures given will not be so convenient. Should, for instance, the total voltage be 1.65 volts, then R2 requires a value of 6.5kΩ. A total voltage of 1.7 volts necessitates a value in R2 of 7kΩ, and so on.

R3 is specified as a 1% or 2% resistor, and R2 should be similarly close in tolerance on value. In practice, it is very probable that R2 will need to be made up of two close tolerance resistors in series. The 6.5kΩ value just mentioned could, for instance, con-

sist of 4.7kΩ and 1.8kΩ in series.

When the voltage checks just described have been completed, the upper end of R1 may then be connected to the transformer secondary, as in Fig.1, and the remainder of the wiring completed.

COMPONENTS

Virtually the only component which requires special comment is the mains transformer. This can be a small heater transformer having two separate 6.3 volt secondaries which may be connected in series. A secondary current rating of at least 0.5 amp is preferable, so that the transformer is only lightly loaded and its windings run cool. The two diodes are specified as 1N4002, but they may be any other diodes in the series 1N4001 to 1N4007. These are chosen as they have a relatively linear forward voltage — forward current curve from 10 to 100mA.

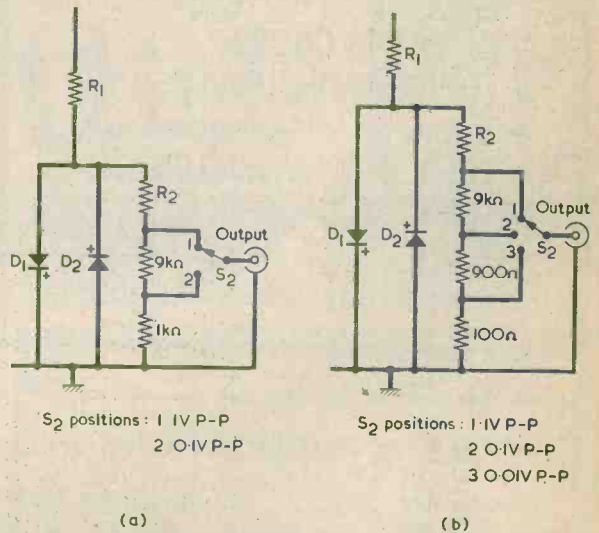

S2 positions: 1 I V P-P
 2 0 I V P-P

S2 positions: 1 I V P-P
 2 0 I V P-P
 3 0 I V P-P

Fig. 4(a). Circuit modification permitting low output voltages to be obtained
 (b). With this circuit there are three output voltages

Outputs lower than 1 volt peak-to-peak may be readily obtained by the simple process of splitting up R3 into sections with the requisite resistance. Fig.4(a) shows the resistances required for peak-to-peak outputs of 1 volt and 0.1 volt, whilst in Fig. 4(b) the outputs are 1 volt, 0.1 volt and 0.01 volt.

**Essential
for the
Short Wave
Enthusiast**

THE RADIO AMATEUR OPERATOR'S HANDBOOK

13TH EDITION

MAKE SURE OF YOUR COPY NOW!

88 PAGES ONLY 70p P. & P. 12p



- ★ AMATEUR PREFIXES
 - ★ AMATEUR CODES
 - ★ LOCAL TIME CONVERSIONS
 - ★ 8 MAPS
 - ★ FREQUENCY/WAVELENGTH CONVERSION TABLES
 - ★ POST OFFICE REGULATIONS
- MANY OTHER ESSENTIAL ITEMS

SIMPLE SHORT-WAVE RECEIVERS



If you are interested in the hobby of receiver construction and short wave listening this is the book for you. It covers the whole field of s.w.l'ing from construction to operating - both Broadcast and Amateur bands. It explains how the circuits work, how to assemble the parts, how to wire-up the circuits with point-to-point wiring diagrams, step-by-step instructions and how to test and operate the completed projects.

by F. A. Baldwin

- ★ FOUR DESIGNS - 1, 2 and 3 Valves
 - ★ INTRODUCTION TO SHORT WAVE LISTENING - 14 Comprehensive Sections
 - ★ WORKSHOP PRACTICE
 - ★ SOLDERING NOTES
 - ★ RECEIVER AND BENCH POWER SUPPLIES
- etc. etc.

140 Pages **80p** P. & P. 18p

TO DATA PUBLICATIONS LTD 57 Maida Vale London W9 1SN

Please supply copy(ies) of "Radio Amateur Operators Handbook", Data Book No. 6
 Please supply copy(ies) of "Simple Short Wave Receivers", Data Book No. 19
(Please tick which book is required)

I enclose cheque/crossed postal order for

NAME

ADDRESS

.....

.....

BLOCK LETTERS PLEASE

SMALL ADVERTISEMENTS

Rate: 8p per word. Minimum charge £1.00
Box No. 20p extra

Advertisements must be prepaid and all copy must be received by the 4th of the month for insertion in the following month's issue. The Publishers cannot be held liable in any way for printing errors or omissions, nor can they accept responsibility for the *bona fides* of Advertisers. (Replies to Box Numbers should be addressed to: Box No. —, **Radio and Electronics Constructor**, 57 Maida Vale, London, W9 1SN.

VINTAGE WIRELESS: For:— valves, circuits, components, receivers, books, magazines, repairs and nostalgia in radio 1920 to 1950, contact Tudor Rees (Vintage Services). Send s.a.e. for newsheet or 50p for full 1976 catalogue. 64 Broad Street, Staple Hill, Bristol, BS16 5NL. Telephone: 0272 565472.

TREASURE HUNTERS! Construct, inexpensively, metal detector giving £300 performance. 10 pages, illustrated plans, £1. C. H. Lucas, 241 Upminster Road South, Rainham, Essex.

SERVICE SHEETS for Radios/TV's etc. 50p and s.a.e. Catalogue 20p and s.a.e. Hamilton Radio, 47 Bohemia Road, St. Leonards-on-Sea, Sussex.

VALVES, RADIO, TV, Transmitting, Industrial. 1930 to 1976. 2,500 types. Many obsolete. List 20p. S.A.E. for quotation. We wish to buy all types of new and boxed valves. Wholesalers, dealers, etc., stocks purchased. Cox Radio (Sussex) Ltd., The Parade, East Wittering, Sussex. Telephone: West Wittering 2023.

WANTED TO PURCHASE: large and small quantities of transistors, diodes, I.C.s, etc. Immediate requirement for 10,000 BC109 transistors. Send samples/lists of any surplus components. Elekon Enterprises, 224a St. Paul's Road, Highbury Corner, London N1 2LJ. Telephone: 01-359 4224.

VACUUM FORMING MACHINES. Mfg. to retail at £30+. My price £12.50 plus 75p post & packing. S.A.E. for particulars. Wm. Bonner, 10 Qundon House, Sutton Way, London W.10.

WANTED TO PURCHASE: All early books on radio, preferably before 1925. Box No. 282.

UNIQUE "GLOBE-KING" VHF KITS. 80-180MHz. Receiver, tuner, converter. World wide sales. Send £6.00 or s.a.e. for free literature. Johnsons Radio (C), 17 Solitaire Avenue, Worcester, WR2 5PP.

METAL BOXES/INSTRUMENT CASES. Range of over 100 standard sizes with punched holes to your specification if required. B.M.S. cut to size. Components. Audio equipment, kits and complete. 2 x 6 1/2 p stamps for lists. Nottingham Audio Services, 13/15 Foxhall Road, Nottingham, NG7 6NA.

(Continued on page 771)

ELECTRONI-KIT

**BUILD, DISMANTLE AND REBUILD
OVER 100 DIFFERENT PROJECTS
AND DESIGN YOUR OWN
CIRCUITS TOO**

Radio Receivers & Transmitters, Telephone Amplifiers, Time Buzzers, Battery Checkers, Computer Circuits, Amplifiers, Directional Transmitters, Metal Detectors, Continuity Testers, Electronic Birds, Guns, Metronomes, Sirens, Roulette, etc., etc. **ALL IN ONE KIT**

"... educational kits of exceptional quality" (AUDIO mag)

"... worthwhile ... good value for money" (EVERYDAY ELECTRONICS mag)

Educational manuals included with each kit. No previous experience required. Suitable for beginners and experts too.

100 project kit £19.60 (Add-on kits
45 project kit £15.60 available too)
25 project kit £12.10

Prices include Manuals, Batteries, VAT and p&p
Cheque/PO (or 11p for illustrated literature) to DEPT. REC.

Satisfaction guaranteed.

**ELECTRONI-KIT LTD, 408 St. John's Street,
London, EC1. [01-278 4579]**

ENGINEERS

FREE



**YOURSELF FOR A
BETTER JOB WITH MORE PAY!**

Do you want promotion, a better job, higher pay? "New Opportunities" shows you how to get them through our low-cost home study course. There are no books to buy and you can pay-as-you-learn.

This helpful guide to success should be read by every ambitious engineer. Send for this helpful 44-page FREE book now. No obligation and nobody will call on you. It could be the best thing you ever did.

CUT OUT THIS COUPON
CHOOSE A BRAND NEW FUTURE HERE!

Tick or state subject of interest. Post to the address below.

- | | | |
|--|--|---|
| Prac. Radio & Electronics (with kit) <input type="checkbox"/> | Motor Mechanics <input type="checkbox"/> | Inst. Eng. & Techs <input type="checkbox"/> |
| Electronic Eng. Cert. <input type="checkbox"/> | C & G Motor V Mechs <input type="checkbox"/> | Maintenance Eng. <input type="checkbox"/> |
| Gen. Elec. Eng. Cert. <input type="checkbox"/> | Gen. Auto Eng. <input type="checkbox"/> | Welding <input type="checkbox"/> |
| C & G Elect. Install. <input type="checkbox"/> | A.M.I.M.I. <input type="checkbox"/> | Computer Prog. <input type="checkbox"/> |
| Elect. Install & Work <input type="checkbox"/> | Air Regm. Brd. Certs. <input type="checkbox"/> | Inst. of Cost - Management Acct. <input type="checkbox"/> |
| C & G Elect. Techs. <input type="checkbox"/> | M.A.A./I.M.I. Dip. <input type="checkbox"/> | Gen. Draughtamp. <input type="checkbox"/> |
| Colour TV Servicing <input type="checkbox"/> | Heat, Ventilating & Air Conditioning <input type="checkbox"/> | A.M.I.E.D. <input type="checkbox"/> |
| C & G Telecomm. Techn. <input type="checkbox"/> | Architectural Draughtmanship & Design <input type="checkbox"/> | Elec. Draughtamp. <input type="checkbox"/> |
| Carpanian's Cert. <input type="checkbox"/> | L.I.O.B. <input type="checkbox"/> | |
| C & G Radio, TV & Electronics Mech. Cert. <input type="checkbox"/> | Carpentry & Joinery <input type="checkbox"/> | |
| Radio & TV Eng. Course <input type="checkbox"/> | Plumbing Tech. <input type="checkbox"/> | |
| Radio Serv. & Rep. <input type="checkbox"/> | General Building <input type="checkbox"/> | |
| Radio Amateur's Exam <input type="checkbox"/> | Painting & Decg. <input type="checkbox"/> | |
| | A.M.S.E. (Mech.) <input type="checkbox"/> | |
| | General Tech. Eng. <input type="checkbox"/> | |

GCE 58 'O' and 'A'
level subjects—over
10,000 group passes

To ALDERMASTON COLLEGE, Dept. TRE 19, READING RG7 4PF

And at our London Advisory Office, 4 Fore Street
Avenue, Moorgate, London. EC2Y 5EJ Tel: 01-628 2721

TRE 19

NAME (Block Capitals Please).....

ADDRESS.....

POSTCODE.....other subjects.....Ase.....

Accredited by C.A.C.C. Member of A.B.C.C.

HOME OF BRITISH INSTITUTE OF ENGINEERING TECHNOLOGY

PRECISION

POLYCARBONATE CAPACITORS

ALL HIGH STABILITY - EXTREMELY LOW LEAKAGE

440V AC (+10%)	63V DC Range	+1%	+2%	+5%
0.1µF (1" x 1/2") 68p	0.47µF	£1.32	77p	51p
0.22µF (1" x 1/2") 86p	1.0µF	£1.56	91p	60p
0.22µF (1" x 1/2") 92p	2.2µF	£1.88	£1.32	75p
0.47µF (1" x 1/2") £1.10	4.7µF	£2.82	£1.88	£1.23
0.5µF (1" x 1/2") £1.16	6.8µF	£3.48	£2.32	£1.47
0.68µF (2" x 1/2") £1.25	10.0µF	£4.98	£3.32	£2.01
1.0µF (2" x 1/2") £1.37	15.0µF	£7.14	£4.78	£2.88
2.0µF (2" x 1/2") £1.95	22.0µF	£9.66	£6.44	£3.90

TANTALUM BEAD CAPACITORS - Values available: 0.1, 0.22, 0.47, 1.0, 2.2, 4.7, 6.8µF at 15V/25V or 35V; 10.0µF at 16V/20V or 25V; 22.0µF at 6V/10V or 16V; 33.0µF at 6V or 10V; 47.0µF at 3V or 6V; 100.0µF at 3V. ALL AT 12p EACH: 10 for £1.10; 50 for £5.00.

TRANSISTORS:

BC107/8/9 9p	*BC183/183L 11p	*BF194 12p	BFY51 20p
BC114 12p	*BC184/184L 12p	*BF196 13p	BFY52 20p
BC147/8/9 10p	*BC212/212L 12p	*BF197 13p	OC71 20p
*BC157/8/9 12p	*BC547 12p	AF178 40p	2N3055 50p
*BC182/182L 11p	*BC558A 12p	BFY50 20p	*2N3702/4 11p

1N914 6p; 8 for 45p; 18 for 90p. 1N916 8p; 6 for 45p; 14 for 90p.
 IS44 5p; 11 for 59p; 26 for £1.00. IN4148 5p; 6 for 27p; 12 for 48p.

LOW PRICE ZENER DIODES: 400mW; Tol. +5% at 5mA. Values available: 3V; 3.6V; 4.7V; 5.1V; 5.6V; 6.2V; 6.8V; 7.5V; 8.2V; 9.1V; 10V; 11V; 12V; 13V; 13.5V; 15V; 16V; 18V; 20V; 22V; 24V; 27V; 30V. All at 7p each; 5 for 33p; 10 for 65p. SPECIAL: 100 Zeners for £6.00.

RESISTORS: High stability low noise carbon film 5%, 1/4 W at 40°C; 1/2 W at 70°C. E12 series only - from 2.2Ω to 2.2MΩ ALL AT 1p EACH; 8p for 10 of any one value; 70p for 100 of any one value. SPECIAL PACK: 10 of each value 2.2Ω to 2.2MΩ (730 resistors) £5.00.

SILICON PLASTIC RECTIFIERS - 1.5 Amp - Brand new wire ended D027: 400 P.I.V. - 7p (4/26p); 400 P.I.V. - 8p (4/30p).

BRIDGE RECTIFIERS: 2 1/2 Amp. 200V - 40p; 350V - 45p; 600V - 55p.

SUBMINIATURE VERTICAL PRESETS - 0.1W only: ALL AT 5p each; 50Ω, 100Ω, 220Ω, 470Ω, 680Ω 1K, 2.2K, 4.7K, 6.8K, 10K, 15K, 22K, 47K, 100K, 220K, 680K, 1M, 2.5M, & 5M.

PLEASE ADD 8% VAT TO ALL ITEMS EXCEPT THOSE MARKED WITH * WHICH ARE 12 1/2%. PLEASE ADD 20p POST AND PACKING ON ALL ORDERS.

Send S.A.E. for lists of additional ex-stock items. Wholesale price lists available to bona-fide companies. ALL EXPORT ORDERS PLEASE ADD COST OF SEA/AIR MAIL.

MARCO TRADING

Dept. P1, The Old School, Edstaston, WEM, Salop. Tel: WHIXALL (Salop) 464/5 (STD 094872) (Props: Minicost Trading Ltd.).

RADIO MODELLER

ELECTRONIC BOOKS

MODEL RADIO CONTROL

Detailing both Theory and Practice, this book, by leading authority Paul Newell, has become the standard reference work. A brief historical survey leads up to a detailed description of proportional systems, with over 100 illustrations, including theoretical circuits and p.c. layouts for an advanced digital system.

134 pages

Price £2.25

U.K. Packing & Postage 32p

theory and practice of

MODEL RADIO CONTROL

development of systems
 proportional explained
 digital system design
 practical remedies and
 full circuit details

ON SALE NOW
 at all leading shops
 or direct from:-

**RADIO MODELLER
 BOOKS DIVISION,
 64 Wellington Road,
 Hampton Hill, Middx.**

BUY THIS BEST SELLER

NEW EDITION
 OF

T.V. FAULT FINDING 405/625 LINES

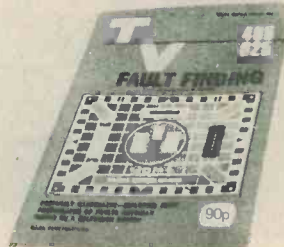

REVISED & ENLARGED

Edited by J. R. Davies

132 pages

PRICE 90p

Over 100 illustrations, including 60 photographs of a television screen after the appropriate faults have been deliberately introduced.

Comprehensive Fault Finding Guide cross-referenced to methods of fault rectification described at greater length in the text.

Price 90p from your bookseller.

or post this Coupon together
 with remittance for £1.08
 (to include postage) to

DATA PUBLICATIONS LTD.

57 Maida Vale, London, W9 1SN

Please send me the 5th revised edition of TV Fault Finding. Data Book No. 5

I enclose cheque/crossed postal order for

NAME

ADDRESS

BLOCK LETTERS PLEASE

SMALL ADVERTISEMENTS

(Continued from page 769)

ORCHARD ELECTRONICS. I.C.'s, TTL, C/Mos, linear, capacitors, resistors (E12), Sil./rectifiers, diodes, LED's, Thyristors, zeners, voltage reg. sil. sockets, bridge rectifiers, potentiometers, presets, triacs, diac, plugs, sockets, cable, Vero. Carefully selected range, excellent despatch service. Same day turn round. S.A.E. for list. Orchard Electronics, Flint House, High Street, Wallingford, Oxon. Telephone: 0491-35529.

FOR SALE: Capacitors, 4mfd, 2000V d.c. wkg., £2; 4mfd, 1000V d.c. wkg., £1.50; 8mfd, 600V d.c. wkg., £1; 5mfd, 3000V d.c. wkg., £1; 0.25mfd, 1200V d.c. wkg., 50p; 0.1mfd, 1000V d.c. wkg., 35p. Valves: 801, 50p; CV345, 25p; 6B4G, 25p; HP4106, 25p; PM2DX, 15p; VR91, 20p; Woden Mic. Trans., M.T.101, £1. Rotary converter, A.M. 10KB/21, 12V d.c., 3.9 amps in, 480V d.c., 0.04 amps out, £1 plus postage. Heavy duty Tannoy hand microphone, £3. Box. No. G299.

THE RADIO AMATEUR INVALID & BEDFAST CLUB is a well established Society providing facilities for the physically handicapped to enjoy the hobby of Amateur Radio. Please become a supporter of this worthy cause. Details from the Hon. Secretary, Mrs. Rita Shepherd, 59 Paintain Road, Loughborough, Leics., LE11 3LZ.

150 COMPONENTS. Semiconductors, capacitors, pots, etc. New, used, surplus. 85p inclusive. Rix, 76 Ber Street, Norwich, Norfolk.

AS USED BY NASA & DEEP SEA RESEARCH. As seen on "Tomorrow's World". Connect to I.F. strip or audio unit only. I.F. Unit £56.70. Audio Unit £42.40. Details s.a.e. M.Fi., 4 Strensham Hill, Moseley, Birmingham 13.

FOR SALE: ORP12 48p, BPX25 £1.10, TBA625B 90p, TBA625C £1.05, LM309K £1.40, TIL108L £1.70, 2N3055 40p, MAN64A, com. anode 0.4" 7 segment & d.p. £1.60. Silicon solar cells .5 volts 40mA, £2.10. Cybertone audio tone generator, variable rate/pitch, 12 volt operation, £3.50. DIL sockets 8, 14 or 16 pin, 12p. Clock crystal 32.768kHz, £2.40. Precision resistor pack, 1/8W -1% - 100ppm, 120-200k, 18 different resistors in each pack, £1.44. P & P 25p extra. For unpriced parts list please send s.a.e. Box No. G308.

WANTED: Van Der Graaf generator. Telephone: 01-863 8604.

WANTED: Buy or loan copy, circuits calibrator Xtal 10, Heathkit TX MT-1, RX RA-1. G3FCK Qthr. Telephone: Newbury 40750.

(Continued on page 772)

TAPETALK THE CLEVER WAY TO LEARN

TWO C60 CASSETTES ENTITLED
'INTRODUCING TRANSISTORS'
will be sent to you by return of post for only
£5.44 plus 55p. VAT/P.Pkg.

**TAPETALK, P.O. BOX 99 (C),
MILTON KEYNES MK3 5BR.
Tel: Milton Keynes (0908) 77710**

Still the *simplest, fastest* way of constructing your electronic circuits. Vero Electronics Ltd manufacture boards to suit most of your requirements, including, VeroStrip, Dual in line I.C. boards, Plain Boards, etc. A new catalogue is available (price 10p + S.A.E. at least 7" x 9")

VERO

VEROBOARD

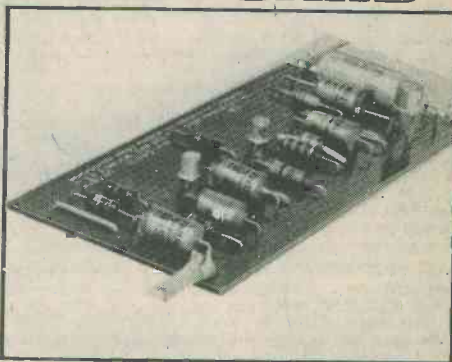

Vero Electronics Limited, Retail Dept.,
Industrial Estate, Chandler's Ford, Hants., SO5 3ZR
Telephone: Chandler's Ford 2956 (STD 04125)

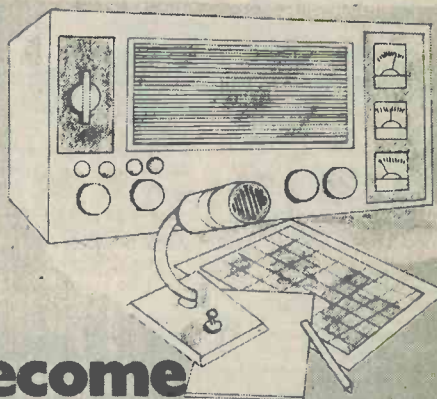

Become a radio amateur.

Learn how to become a radio amateur in contact with the whole world. We give skilled preparation for the G.P.O. licence.

Free!

Brochure, without obligation to:
**BRITISH NATIONAL RADIO
& ELECTRONICS SCHOOL, Dept**
P.O.Box 156, Jersey, Channel Islands.

WAA
REB 76

NAME _____

ADDRESS _____

(Block caps please)

PLAIN-BACKED NEW STYLE SELF-BINDERS

for your other magazines

(max. format 7½" x 9½")

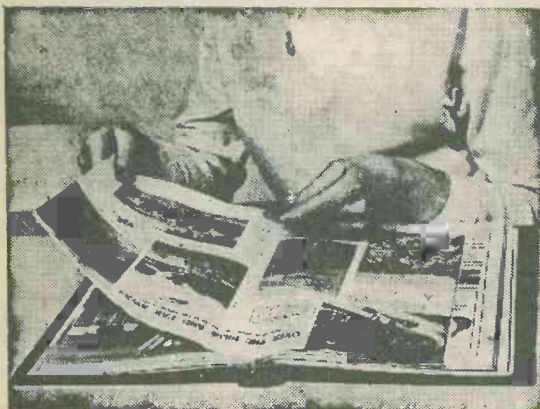

The "CORDEX" Patent Self-Binding Case will keep your copies in mint condition. Issues can be inserted or removed with the greatest of ease. Specially constructed Binding cords are made from Super Linen of great strength, very hard twisted and twice doubled. They are attached to strong RUSTLESS Springs under tension, and the method adopted ensures PERMANENT RESILIENCE of the Cords. Any slack that may develop is immediately compensated for, and the Cords will always remain taut and strong. It is impossible to overstretch the springs, as a safety check device is fitted to each.

COLOURS: MAROON OR GREEN

(If choice not stated, colour available will be sent)

PRICE 95p P. & P. 25p

Available only from:—

Data Publications Ltd.
57 Maida Vale London W9 1SN

SMALL ADVERTISEMENTS

(Continued from page 771)

FOR SALE: Frequency meter TS174 (similar to BC221) 20-280 Mc/s, mains psu, £25. Absorption wavemeters, Marconi TF975, 95kHz/100MHz, £25. STC, R502, 100kHz-48MHz, £20. Signal generators, Marconi TF1446, 85kHz/25MHz, £20. TF801 A/1, 10-300MHz, £30. TF897, 15kHz/35MHz, £40. Advance B4 90kHz/25MHz, £20. Cossor 1049, Mk 3 DB scope, £25. Telequipment 620 scope £30. Metrovick miniscope £20. Avo 7 £14. Avo 8 £20. All in working order. Most have handbooks. S.A.E. enquiries. Carriage extra. Box No. G312.

FREQUENCY LIST TRANSFERS. We have a limited supply of sheets of Dial Frequency Transfers in black. Short Wave frequencies 1.8Mc/s to 32Mc/s and 144Mc/s and 146Mc/s. Includes amateur band marker frequencies at 100kc/s points and other short wave frequencies from 2 to 32 Mc/s at every 500Kc/s points. Each frequency is repeated. Two sheets for 5p., five sheets for 10p., postage 6p. Data Publications Ltd., 57 Maida Vale, London, W9 1SN.

JOIN THE INTERNATIONAL S.W. LEAGUE. Free services to members including Q.S.L. Bureau, Amateur and Broadcast Translation, Technical and Identification Dept. — both Broadcast and Fixed Stations, DX Certificates, contests and activities for the SWL and transmitting members. Monthly magazine, *Monitor*, containing articles of general interest to Broadcast and Amateur SWLs, Transmitter Section and League affairs, etc. League supplies such as badges, headed notepaper and envelopes, QSL cards, etc., are available at reasonable cost. Send for League particulars. Membership including monthly magazines, etc., £3.75 per annum. (U.K. and British Commonwealth), overseas \$10.00 or £4.00. Secretary ISWL, 1 Grove Road, Lydney, Glos., GL15 5JE.

HEATHKIT GR 78 6-BAND RECEIVER. Owing to unfortunate circumstances the above is for sale. Built late 1975. Tested and aligned by Heathkit October 1975. List price £139. Sale price £110 o.n.o. Telephone: Broadway (Worcs.) 3297.

FOR SALE: Single copies *Radio Constructor* June 1955 to October 1955 and complete set from Volume 9 No. 6, January 1956 onward. Also Testgear Acton valved signal generator, little used. Offers to Box No. G313.

WANTED: CW and/or SSB transmitter and exciter unit, with about 10 watts r.f. output on 28MHz. Suitable for drawing OSCAR transverter. VFO or xtal. G2UK, 21 Romany Road, Oulton Broad, Lowestoft, Suffolk, NR32 3PJ.

FOR SALE: *Radio Control Models & Electronics* May 1960 to December 1963. *Radio Constructor* August 1961 to December 1967. Offers invited. Tremlett, 17 Radnor Road, Horfield, Bristol, BS7 8QS.

POSTAL ADVERTISING? This is the Holborn Service. Mailing lists, addressing, enclosing, wrapping, facsimile letters, automatic typing, copy service, campaign planning, design and artwork, printing and stationery. Please ask for price list. — The Holborn Direct Mail Company Capacity House, 2-6 Rothsay Street, Tower Bridge Road, London, S.E.1. Telephone: 01-407 6444.

(Continued on page 773)

RADIO & ELECTRONICS CONSTRUCTOR

SMALL ADVERTISEMENTS

(Continued from page 772)

PERSONAL

JANE SCOTT FOR GENUINE FRIENDS. Introductions to opposite sex with sincerity and thoughtfulness. Details free. Stamp to: Jane Scott, 3/Con North St. Quadrant, Brighton, Sussex, BN1 3GJ.

IF YOU HAVE ENJOYED A HOLIDAY on the Norfolk Broads, why not help to preserve these beautiful waterways. Join the Broads Society and play your part in determining Broadlands future. Further details from: - The Hon. Membership Secretary, The Broads Society, "Icknield," Hilly Plantation, Thorpe St. Andrew, Norwich, NOR 85S.

MEET PEOPLE who enjoy doing your kind of thing. Dates in all areas, selected by computer. All ages, interests and personality types. Write: SIM (Dept. 936), Braemar House, Queens Road, Reading.

SPONSORS required for exciting scientific project. Norwich Astronomical Society are building a 30" telescope to be housed in a 20' dome of novel design. All labour being given by volunteers. Already supported by Industry and Commerce in Norfolk. Recreational. Educational. You can be involved. Write to: NAS Secretary. The Manse, Back Lane, Wymondham, Norfolk.

ESSEX GARDENERS. Buy your Bedding and rock plants, shrubs, etc., also cacti from May's Nurseries, 608 Rayleigh Road, Hutton, Brentwood, Essex. Callers only. Monday to Saturday.

DISABLED YOUNG MAN looking for electronic wiring assembly (outwork) for assembly in his home workshop. Box No. G307.

TAPETALK The CLEVER way to LEARN

This Month's Special Offer:
TWO C60 Cassettes entitled
INTRODUCING ELECTRONICS
will be sent to you by return of post for only
£5.44 plus 55p VAT/P. Pkg.
TAPETALK, P.O. Box 99 (C)
Milton Keynes MK3 5BR
Tel: Milton Keynes (0908) 77710

MULLARD FERRITE CORES — LA3 100 to 500 kHz, 54p; LA5 30 to 100 kHz, 81p; LA7 < 10 kHz, 81p; LA13 for W.W. Oscilloscope, £1.50.

SPECIAL OFFER — Metallised Polyester Capacitors by Erie, Mullard, etc. Values include: .01/160V, .01/250V, .015/160V, .022/160V, .033/160V, .047/160V, .068/160V, .1/160-250V, .22/160V, etc. This is a bargain not to be missed. 100 for £2.00.

1N4148 SWITCHING DIODES, 10 for 30p; 50 for £1.25; 100 for £1.50; 1,000 for £10.00

TRANSISTORS — All branded BC147, BC148, BC149, BC157, BC158, BC159, BF194, BF195, BF196, BF197, 8p each or 100 for £8.00.

Please note all prices include UK Postage and appropriate VAT @ 8% or 12½%

MAIL ORDER ONLY
XEROZA RADIO
1 EAST STREET, BISHOP'S TAWTON, DEVON

REVOR OPTICAL & TECHNICAL

12/13 HENRIETTA ST.,
LONDON W.C.2
Tel. 01-836 4536

£8.50

**POST
FREE**

4" dia. lens

FLEXIBLE MAGNIFIER

WITH CAST IRON BASE,
PRECISION GROUND AND
POLISHED LENS, CHROME PLATED
FRAME AND FLEXIBLE TUBE.
IDEAL FOR HOBBIES, AND
DETAILED WORK WHICH REQUIRES
BOTH HANDS FREE.

CALLERS WELCOME

(Subject to price ruling at the time of issue)

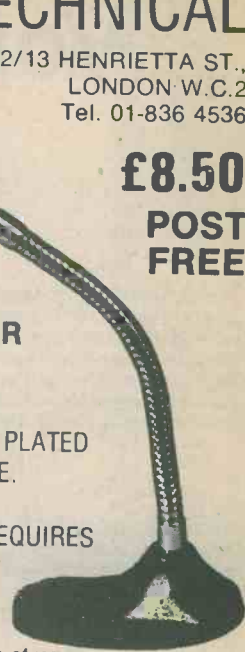

ENGINEERS

FREE

YOURSELF FOR A

BETTER JOB WITH MORE PAY!

Do you want promotion, a better job, higher pay? "New Opportunities" shows you how to get them through our low-cost home study course. There are no books to buy and you can pay-as-you-learn.

This helpful guide to success should be read by every ambitious engineer. Send for this helpful 44-page FREE book now. No obligation and nobody will call on you. It could be the best thing you ever did.



**POST
NOW**

CUT OUT THIS COUPON
CHOOSE A BRAND NEW FUTURE HERE!

Tick or state subject of interest. Post to the address below.

- | | | |
|---|--|---|
| Build-As-You-Learn | Electronic Engineering | Transistor Technology |
| PRACTICAL RADIO AND ELECTRONICS (with kit) | Computer Electronics | CITY & GUILDS Installations and Wiring |
| Electrical Engineering | Computer Programming | CITY & GUILDS Electrical Technicians |
| Electrical Installations and Wiring | Colour TV Servicing | CITY & GUILDS Telecommunications |
| Electrical Draughtsmanship | C & G Radio, TV and Electronic Mechanics | Radio Amateurs' Exam etc. etc. |
| Electrical Mathematics | General Radio and TV Engineering | G.C.E. 'S' 'O' & 'A' LEVELS |
| | Radio Servicing, Maintenance and Repairs | Coaching for many major examinations |

To **ALDERMASTON COLLEGE, Dept. ERE 19, READING RG7 4PF**
Also at our London Advisory Office, 4 Fore Street
Avenue, Moorgate, London, EC2Y 5EJ Tel: 01-528 2721 **ERE 19**

NAME (Block Capitals Please)

ADDRESS

POSTCODE

Other subjects:

Accredited by C.A.C.C.

Age

Member of A.B.C.C.

HOME OF BRITISH INSTITUTE OF ENGINEERING TECHNOLOGY

INDEX

VOLUME TWENTY-NINE

August 1975-July 1976

AMPLIFIERS

CA3048 and CA3052 Amplifier Arrays, <i>by A. Foord</i>	89	Sept. '75
General Purpose I.C. Amplifier, <i>by F. G. Rayer</i>	726	July '76
Guitar Headphone Amplifier, <i>by M. G. Argent</i>	438	Feb. '76
Stereo I.C. Amplifier, <i>by R. A. Penfold</i>	488	Mar. '76
The 6/12 Amplifier — Part 1, <i>by J. T. Neill</i>	206	Nov. '75
The 6/12 Amplifier — Part 2, <i>by J. T. Neill</i>	284	Dec. '75
The SN76023N Power Amplifier, <i>by P. R. Arthur</i>	239	Nov. '75

AMPLIFIER ANCILLARIES

Added Ambience, <i>by R. N. Soar</i>	223	Nov. '75
Ambiphonic Adapter — Part 1, <i>by R. A. Penfold</i>	534	Apl. '76
Ambiphonic Adapter — Part 2, <i>by R. A. Penfold</i>	622	May '76
Audio Control Circuits — 1, <i>by P. R. Arthur</i>	735	July '76
4 Channel Stereo Mixer, <i>by R. A. Penfold</i>	406	Feb. '76

ELECTRONICS

Automatic Garage Light, <i>by G. A. French</i>	86	Sept. '75
Battery Condition Indicator, <i>by P. R. Arthur</i>	174	Oct. '75
Battery Voltage Monitor, <i>by G. A. French</i>	416	Feb. '76
Burglar Alarm Circuits, <i>by G. A. French</i>	669	June '76
Capacitor Combination Lock, <i>by G. A. French</i>	475	Mar. '76
Cassette Recorder Battery Eliminator for Cars, <i>by S. V. Essex</i>	344	Jan. '76
Compact Stabilized Power Supply, <i>by S. V. Essex</i>	364	Jan. '76
Comparators, <i>by D. Snaith</i>	110	Sept. '75
Dual Metronome, <i>by P. R. Arthur</i>	598	May '76
Dual Voltage Power Supply, <i>by S. V. Essex</i>	106	Sept. '75
Electronic Lock, <i>by Phoebus Polydorides</i>	440	Feb. '76
Electronic Siren, <i>by M. Harding</i>	44	Aug. '75
Foldback Limiting Voltage Regulators, <i>by J. B. Dance</i>	170	Oct. '75
Improved Courtesy Light for Cars, <i>by J. Hart</i>	14	Aug. '75
Inexpensive Morse Oscillator, <i>by D. Snaith</i>	569	Apl. '76
L.E.D. Constant Current Sources, <i>by G. A. French</i>	342	Jan. '76
Multi-Way Latch Circuits, <i>by G. A. French</i>	214	Nov. '75
New Multiple Tuning Diodes, <i>by J. B. Dance</i>	42	Aug. '75
Nickel Cadmium Cell Charger, <i>by A. P. Roberts</i>	664	June '76
"One-Shot" Electronic Timer, <i>by G. A. French</i>	612	May '76
Parallel S.C.R. Combination Lock, <i>by Craig K. Sellen</i>	78	Sept. '75
Power Supply for Op-Amps, <i>by A. P. Roberts</i>	224	Nov. '75
Power Supply with Electronic Fuse, <i>by A. P. Roberts</i>	546	Apl. '76
Resistive Bandsread Control, <i>by S. L. Martin</i>	686	June '76
Schmitt Relay Flasher, <i>by J. R. Davies</i>	220	Nov. '75
Sequential Relay Switch, <i>by T. Miles</i>	602	May '76
The "Tantaliser" — An Electronic Game, <i>by G. A. French</i>	146	Oct. '75
Thyristor Bistable, <i>by J. R. Davies</i>	16	Aug. '75
Touch Switch, <i>by S. V. Essex</i>	298	Dec. '75
Transistor D.C. Loads, <i>by R. J. Caborn</i>	430	Feb. '76
Two Transistor Touch Button, <i>by D. W. Savage</i>	692	June '76
Unity Gain Inverter, <i>by J. R. Davies</i>	278	Dec. '75
Versatile Light Alarm, <i>by J. R. Davies</i>	142	Oct. '75
Voltage-Conscious Thyristor Circuits, <i>by G. A. French</i>	732	July '76
Water Level Sensor, <i>by R. Desmond</i>	435	Feb. '76
Wide Range Metronome, <i>by M. G. Robertson</i>	233	Nov. '75
Zener-Transistor Circuits, <i>by F. T. Jones</i>	704	June '76

GENERAL

Choosing the Right Battery, <i>by Vivian Capel</i>	293	Dec. '75
Collecting Q.S.L. Cards, <i>by F. G. Rayer</i>	502	Mar. '76
Constructor's Crossword, <i>by D. P. Newton</i>	81	Sept. '75

Electronic Oddities, by <i>R. River</i>	235	Nov. '75
Human Cell, by <i>D. W. Savage</i>	112	Sept. '75
New Educational Aid	46	Aug. '75
Oil Rig Transducers	437	Feb. '76
Oscar 8, by <i>Arthur C. Gee</i>	690	June '76
Q.S.L. Cards — How to Collect Them, by <i>Steve A. Money</i>	47	Aug. '75
Stereo Disc Reproduction, by <i>P. R. Arthur</i>	84	Sept. '75
Substituting by Silicon Rectifiers, by <i>F. G. Rayer</i>	217	Nov. '75
Ten Tips with Insulating Tape, by <i>K. Harker</i>	150	Oct. '75
The Oscars, by <i>Arthur C. Gee</i>	432	Feb. '76
The "Variable Zener", by <i>T. Miles</i>	348	Jan. '76
Touch Tuning Control, by <i>J. B. Dance</i>	282	Dec. '75
Vertically Radiating Antenna for Oscar, by <i>Arthur C. Gee</i>	108	Sept. '75
Wind Force Indicator, by <i>V. S. Evans</i>	500	Mar. '76
Winding Coils, by <i>C. F. Edwards</i>	495	Mar. '76
Winding Coils for Industry	496	Mar. '76
Workshop Aids	565	Apl. '76

IN YOUR WORKSHOP

Binary Gambling Device	698	June '76
Constant Current Paradox	442	Feb. '76
Electronics A-Z	759	July '76
I.F. Instability	376	Jan. '76
Integrated Circuit Wheatstone Bridge	179	Oct. '75
Logic and de Morgan's Theorem	114	Sept. '75
Mains-Battery Supplies	50	Aug. '75
Readers' Hints	635	May '76
Servicing a Record Player	507	Mar. '76
SN76013 Audio Amplifier I.C.	307	Dec. '75
TV Line and Vertical Blanking Circuits	243	Nov. '75
Video Amplifying Stages	571	Apl. '76

RECEIVERS

Broadcast Band Receiver, by <i>J. R. Davies</i>	161	Oct. '75
Headphone Receiver, by <i>R. A. Penfold</i>	334	Jan. '76
Homodyne S.S.B. Receiver for 80 Metres — Part 1, by <i>R. A. Penfold</i>	680	June '76
Homodyne S.S.B. Receiver for 80 Metres — Part 2, by <i>R. A. Penfold</i>	756	July '76
"IC Plus Two" Receiver, by <i>A. P. Roberts</i>	616	May '76
160-80 Metre Band Receiver, by <i>A. P. Roberts</i>	480	Mar. '76
Single Range Oscillator Superhet — Part 1, by <i>F. G. Rayer</i>	552	Apl. '76
Single Range Oscillator Superhet — Part 2, by <i>F. G. Rayer</i>	632	May '76
The "Drachma" S.W. and V.H.F. Portable — Part 1, by <i>Sir Douglas Hall, K.C.M.G.</i>	270	Dec. '75
The "Drachma" S.W. and V.H.F. Portable — Part 2, by <i>Sir Douglas Hall, K.C.M.G.</i>	350	Jan. '76
The "Superalphadyne" Portable Receiver — Part 1, by <i>Sir Douglas Hall, K.C.M.G.</i>	606	May '76
The "Superalphadyne" Portable Receiver — Part 2, by <i>Sir Douglas Hall, K.C.M.G.</i>	694	June '76
2 Transistor Personal Receiver, by <i>A. P. Roberts</i>	418	Feb. '76

RECEIVER ANCILLARIES

F.M. Signal Booster, by <i>A. Sydenham</i>	20	Aug. '75
Ten Metre Band Aerials, by <i>F. G. Rayer</i>	94	Sept. '75

TRANSMITTING

Amateur Radio Teleprinter Speed Standards, by <i>Arthur C. Gee</i>	169	Oct. '75
Another Versatile Vertical, by <i>V. S. Evans</i>	167	Oct. '75
One Valve Working on "160" and "80", by <i>A. S. Carpenter</i>	752	July '76
Ten Metre Band Aerials, by <i>F. G. Rayer</i>	94	Sept. '75
30 Watt Transmitter — Part 2, by <i>F. G. Rayer</i>	26	Aug. '75
Universal V.F.O., by <i>F. G. Rayer</i>	371	Jan. '76
Vertically Radiating Antenna for Oscar, by <i>Arthur C. Gee</i>	108	Sept. '75

TEST EQUIPMENT

Add-On VU Meter, by <i>P. R. Arthur</i>	628	May '76
Diode Polarity Indicator, by <i>N. R. Wilson</i>	566	Apl. '76
Discriminating Continuity Tester, by <i>F. G. Lloyd</i>	504	Mar. '76
4-Way Beam Splitter, by <i>B. Woodland and R. J. Woodland</i>	744	July '76
"In-Situ" Transistor Checker, by <i>G. A. French</i>	275	Dec. '75
Integrated Circuit Signal Generator — Part 1, by <i>John Lewis</i>	32	Aug. '75
Integrated Circuit Signal Generator — Part 2, by <i>John Lewis</i>	93	Sept. '75
Integrated L.F. Function Generator — Part 1, by <i>Steve A. Money</i>	424	Feb. '76
Integrated L.F. Function Generator — Part 2, by <i>Steve A. Money</i>	497	Mar. '76
Low Cost Wobulator, by <i>P. R. Arthur</i>	470	Mar. '76
Low-Value Ohmmeter, by <i>M. G. Robertson</i>	674	June '76
Measuring Mains Current, by <i>J. Sneddon</i>	741	July '76
New Transistorised Oscilloscope — Part 1, by <i>R. A. Penfold</i>	96	Sept. '75
New Transistorised Oscilloscope — Part 2, by <i>R. A. Penfold</i>	154	Oct. '75
New Transistorised Oscilloscope — Part 3, by <i>R. A. Penfold</i>	229	Nov. '75

Novel Transistor Gain Meter, by G. A. French	542	Apl.	'76
Oscilloscope Trace Doubler, by A. P. Roberts	356	Jan.	'76
Simple Transistor Tester, by Brian Reay	688	June	'76
Timebase Generator, by P. R. Arthur	560	Apl.	'76
Voltage Calibrator for Oscilloscopes, by C. F. Edwards	766	July	'76
Voltmeter With a Memory, by G. A. French	23	Aug.	'75
Wien Bridge Audio Signal Generator, by R. A. Penfold	287	Dec.	'75

CAN ANYONE HELP?

25 Aug. '75	153 Oct. '75	339 Jan. '76	705 June '76
-------------	--------------	--------------	--------------

LETTERS

39 Aug. '75	559 Apl. '76	641 May '76
-------------	--------------	-------------

NEWS AND COMMENT

18 Aug. '75	82 Sept. '75	148 Oct. '75	212 Nov. '75
280 Dec. '75	340 Jan. '76	414 Feb. '76	478 Mar. '76
540 Apl. '76	604 May '76	662 June '76	730 July '76

NEW PRODUCTS

238 Nov. '75	384 Jan. '76	513 Mar. '76	627 May '76
673 June '76			

RADIO TOPICS

56 Aug. '75	120 Sept. '75	305 Dec. '75	382 Jan. '76
448 Feb. '76	687 June '76	764 July '76	

RECENT PUBLICATIONS AND BOOK REVIEWS

49 Aug. '75	145 Oct. '75	283 Dec. '75	413 Feb. '76
545 Apl. '76	668 June '76		

SHORT WAVE NEWS

40 Aug. '75	104 Sept. '75	176 Oct. '75	236 Nov. '75
296 Dec. '75	362 Jan. '76	422 Feb. '76	486 Mar. '76
563 Apl. '76	614 May '76	678 June '76	742 July '76

TRADE NEWS

31 Aug. '75	113 Sept. '75	178 Oct. '75	370 Jan. '76
506 Mar. '76	568 Apl. '76	641 May '76	751 July '76

ELECTRONICS DATA

No. 1 Series Resonance	iii Aug. '75	No. 7 Band-Pass Filters	iii Feb. '76
No. 2 Parallel Resonance	iii Sept. '75	No. 8 Variable Capacitors	iii Mar. '76
No. 3 Follow the Arrows	iii Oct. '75	No. 9 Trimmer Capacitors	iii Apl. '76
No. 4 Switches	iii Nov. '75	No. 10 Time Constant	iii May '76
No. 5 Wavelength and Frequency	iii Dec. '75	No. 11 What Resistors Do	iii June '76
No. 6 Mains Transformers	iii Jan. '76	No. 12 What Capacitors Do	iii July '76